

REV	DESCRIPTION	DATE	ECN #	APPR
A	INITIAL RELEASE	00-XXX-19	XXXXX	MM

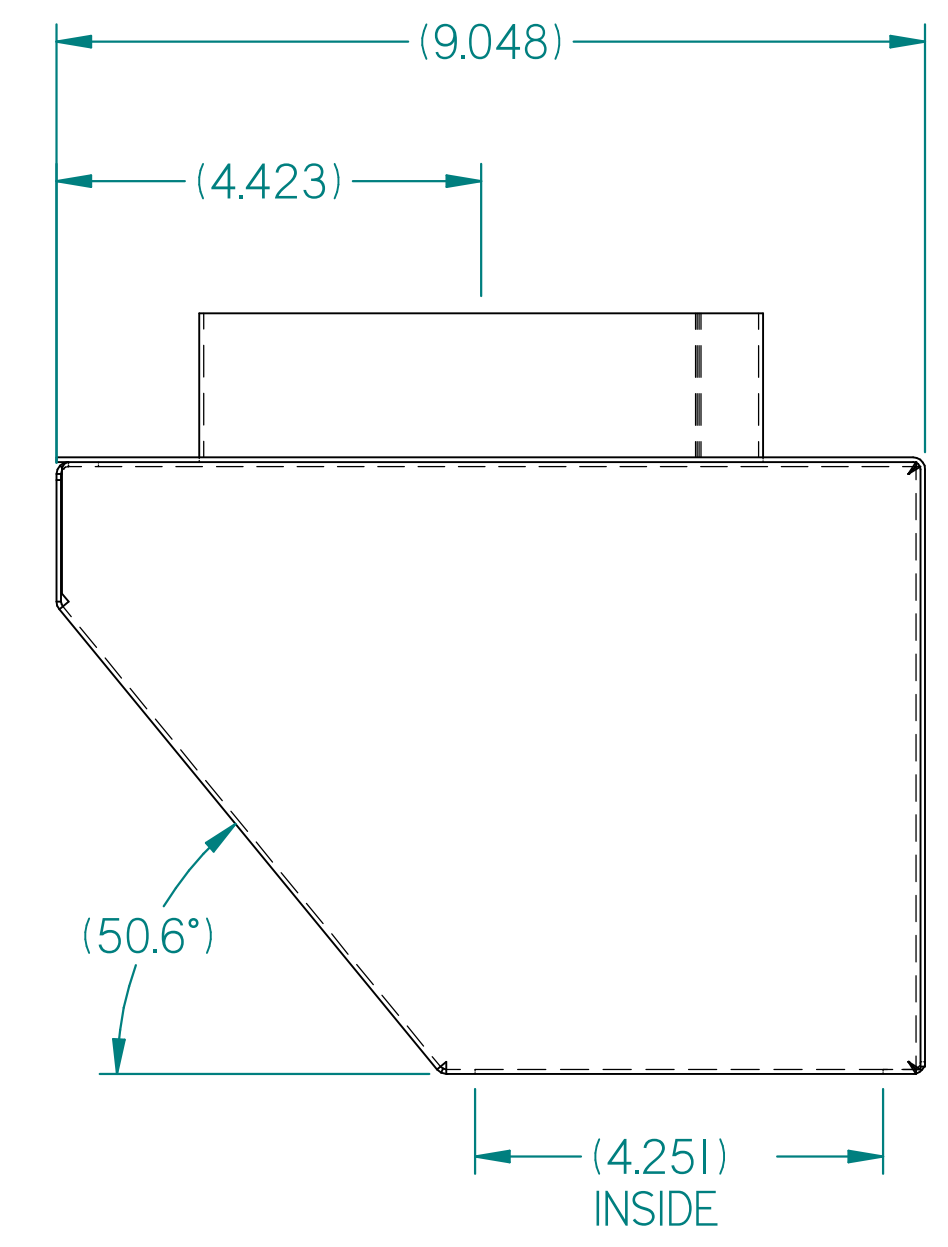
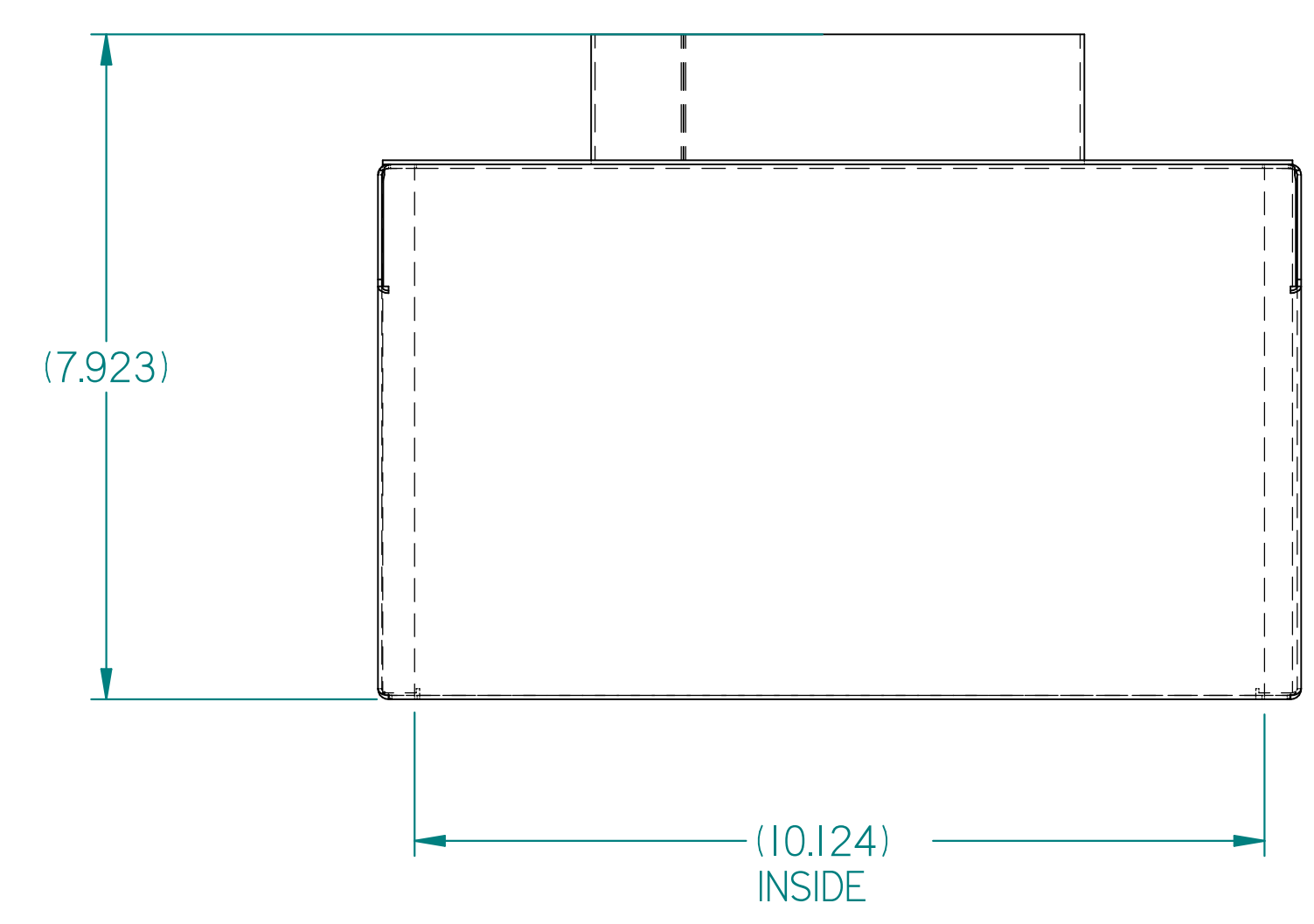
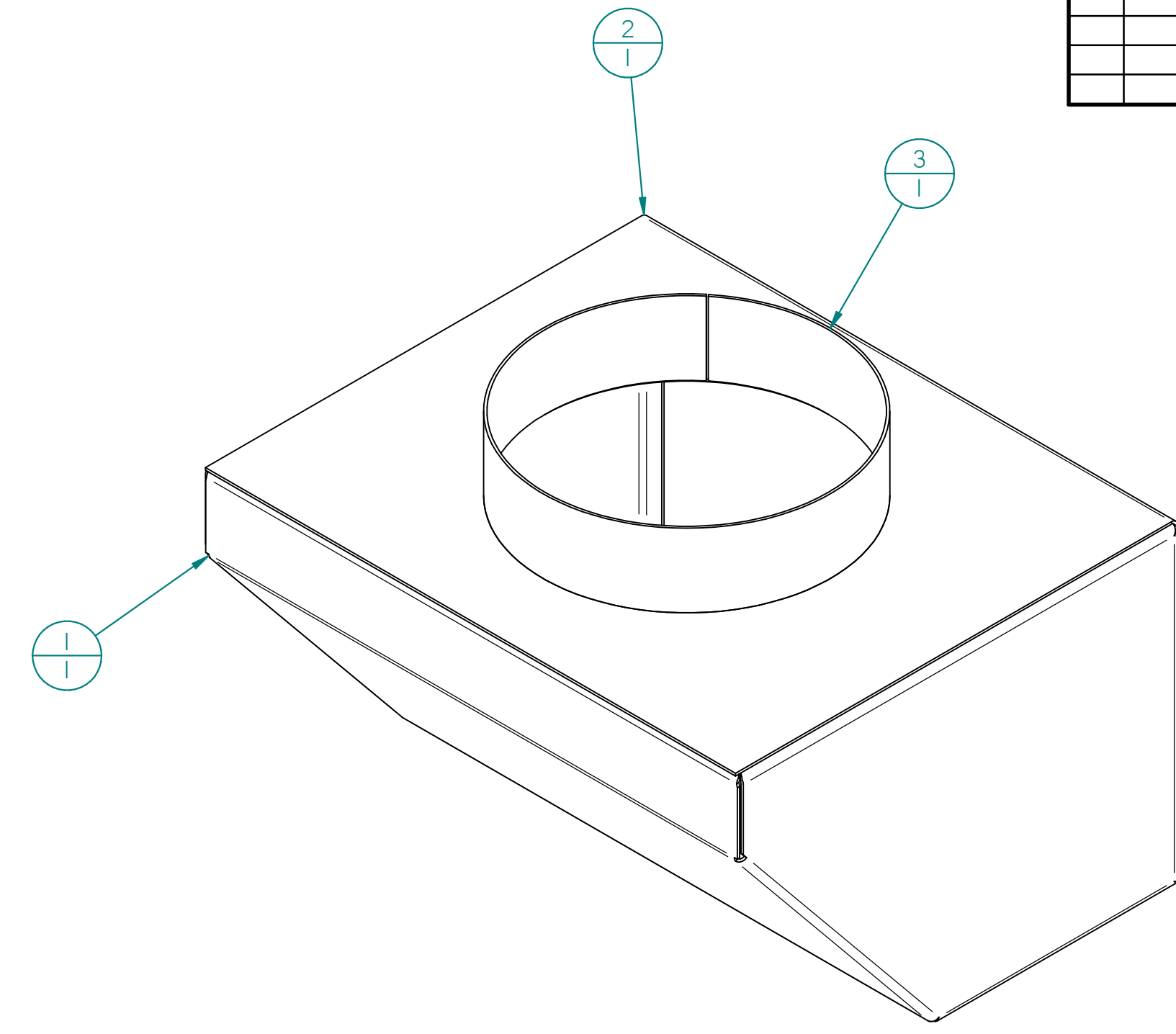
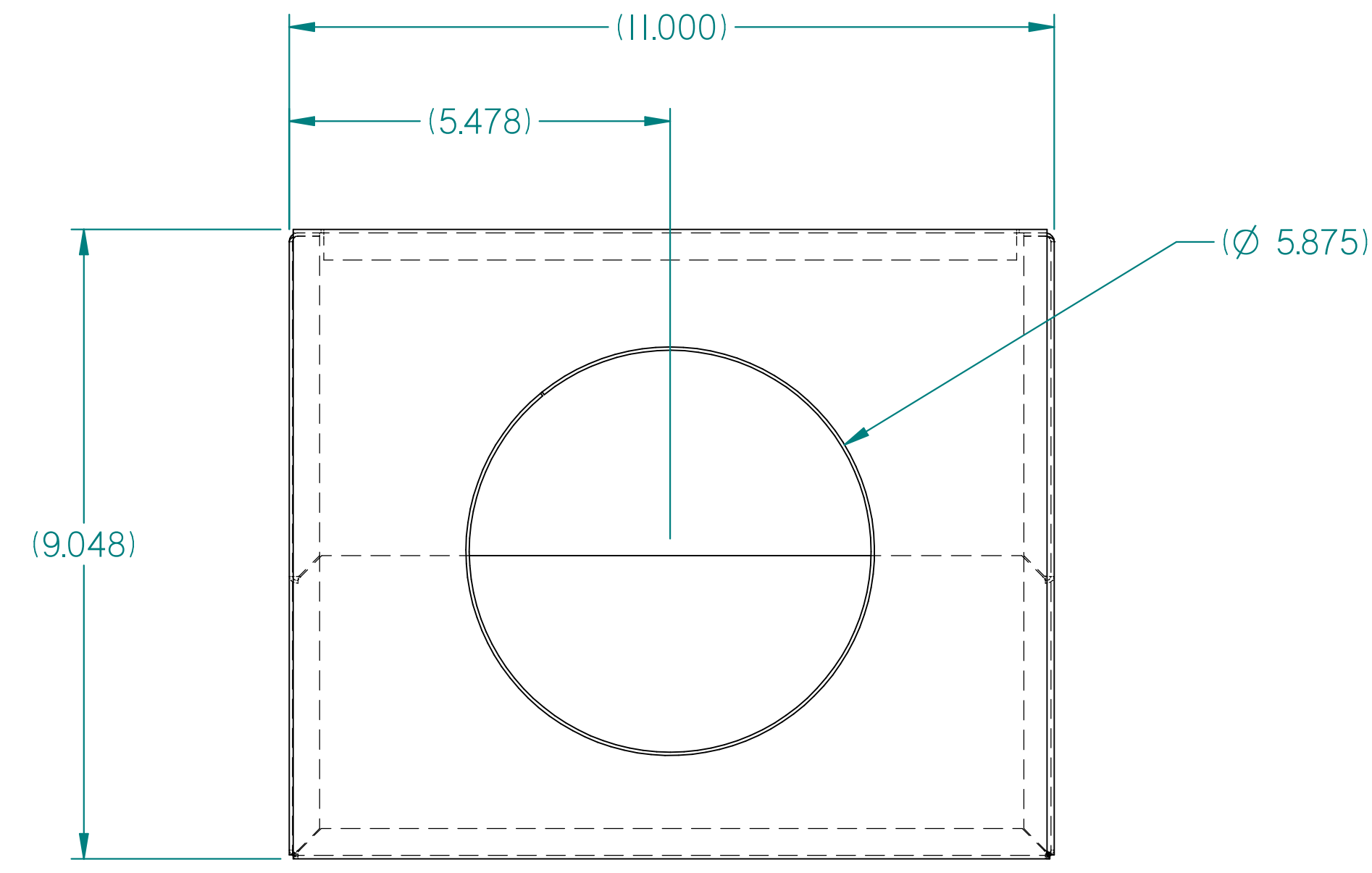

MOPEC LEGAL NOTE
 THIS DOCUMENT CONTAINS PROPRIETARY INFORMATION OF MOPEC, AND MAY NOT BE COPIED IN WHOLE OR PART, AND NO USE SHALL BE MADE OF IT OTHER THAN FOR WHICH IT HAS BEEN SUBMITTED WITHOUT THE WRITTEN PERMISSION OF A MOPEC MANAGER
 MOPEC 2026

UNLESS OTHERWISE SPECIFIED ALL DIMENSIONS IN INCHES
 TOLERANCES 0.0 ± 0.1 in
 0.00 ± 0.05 in
 0.000 ± 0.010 in
 0.0000 ± 0.0010 in
 ANGLES ± 0.5°
 BREAK ALL CORNERS 0.063 X 45°
 ALL FILLET RADII R0.063 / 0.125 in
 INSPECT OVAL DIMENSIONS

MATERIAL
 MATERIAL USAGE Error: No reference
 FINISH Error: No reference

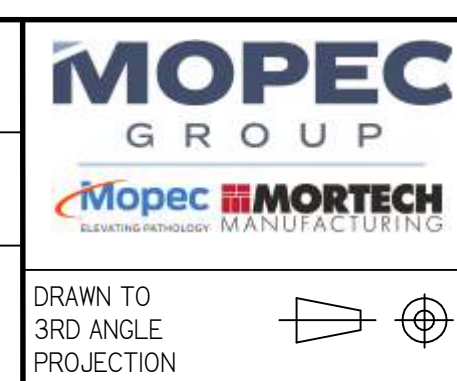

DRAWN BY: jrudolph
 DATE: 4/9/2026
 CHECKED BY: ---
 DATE: 4/9/2026
 APPROVED BY: M.McCLAIN
 DATE: 4/9/2026

PART NUMBER: OA-210
 DESCRIPTION: ---
 SIZE: A2 FILE NAME: OA-210.dft
 SCALE: 1:2
 DO NOT SCALE IF IN DOUBT ASK
 SHEET 1 OF 1

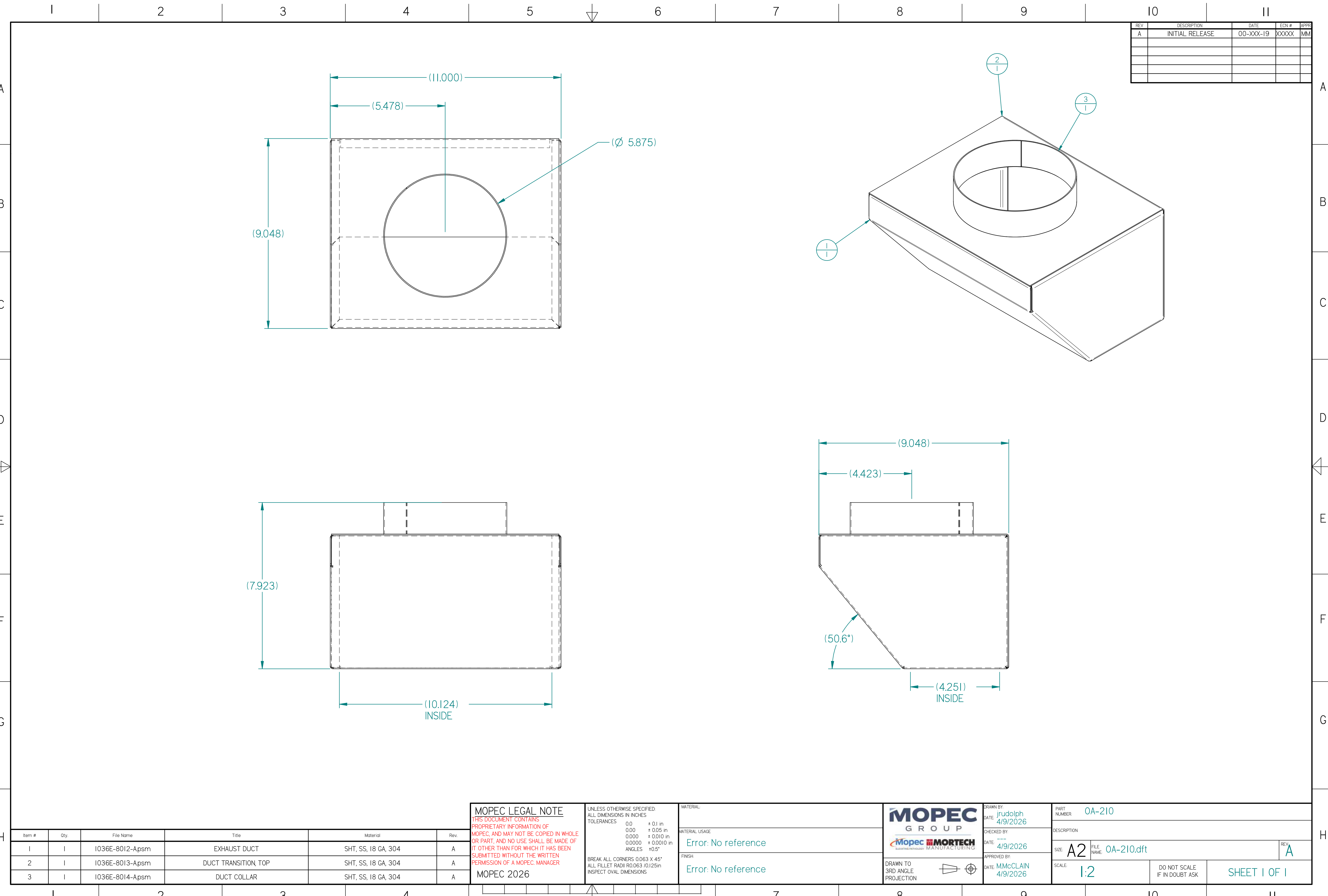

OA-210.dft