

NOTES: UNLESS OTHERWISE SPECIFIED

1. APPLICABLE STANDARDS AND SPECIFICATIONS;
ASME Y14.5-2009, DIMENSIONING AND TOLERANCING
ASME Y14.5-2007, ABBREVIATIONS

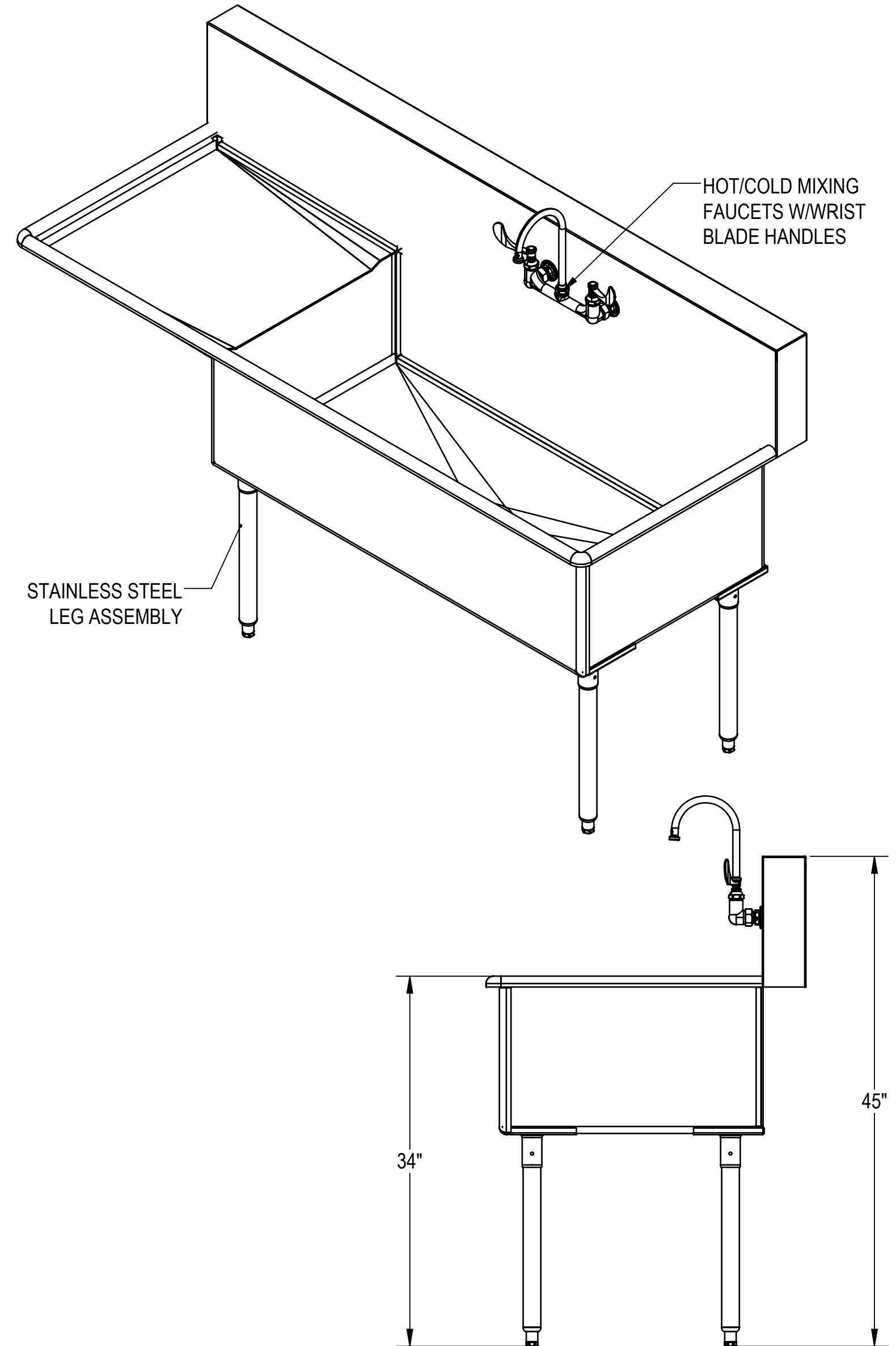
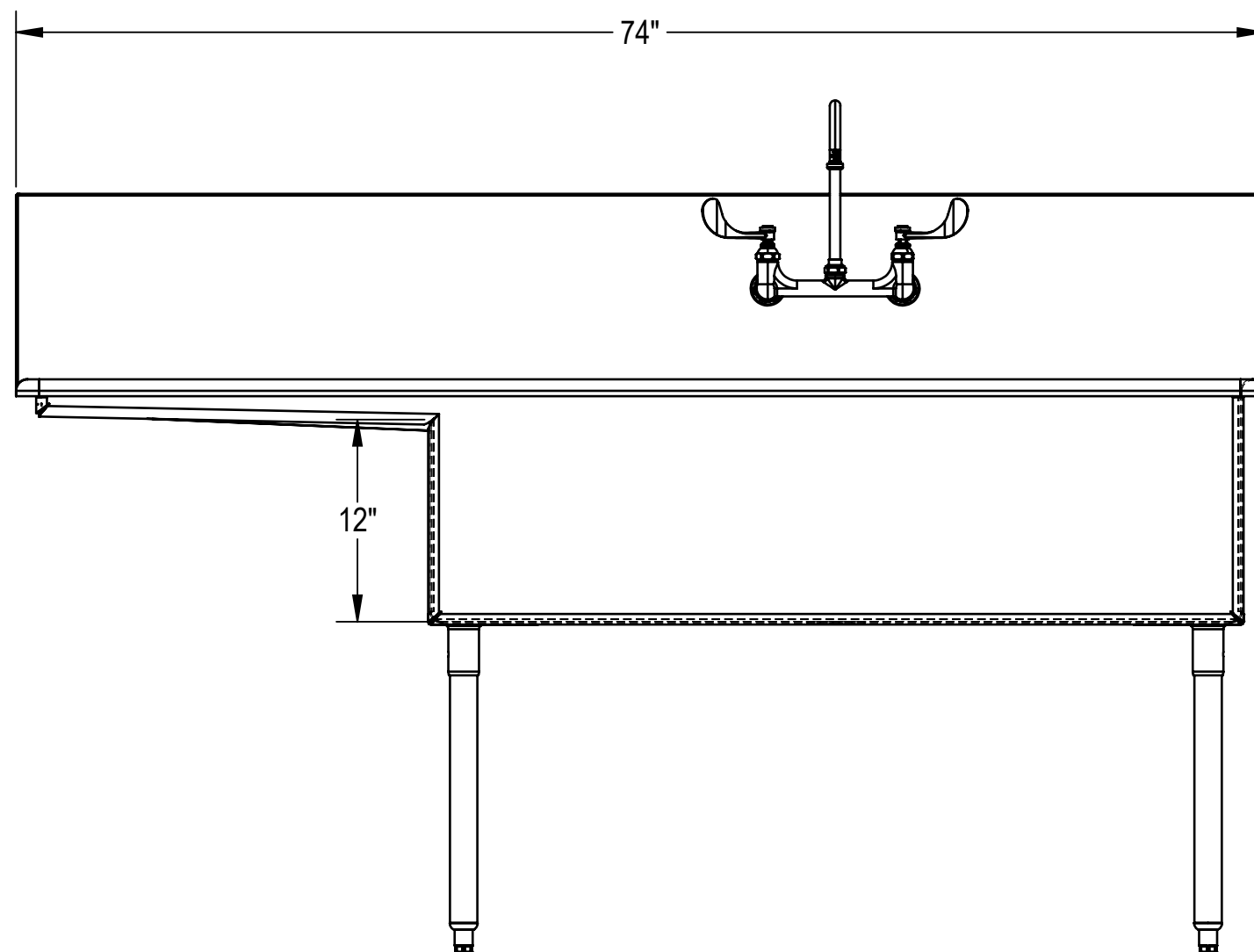
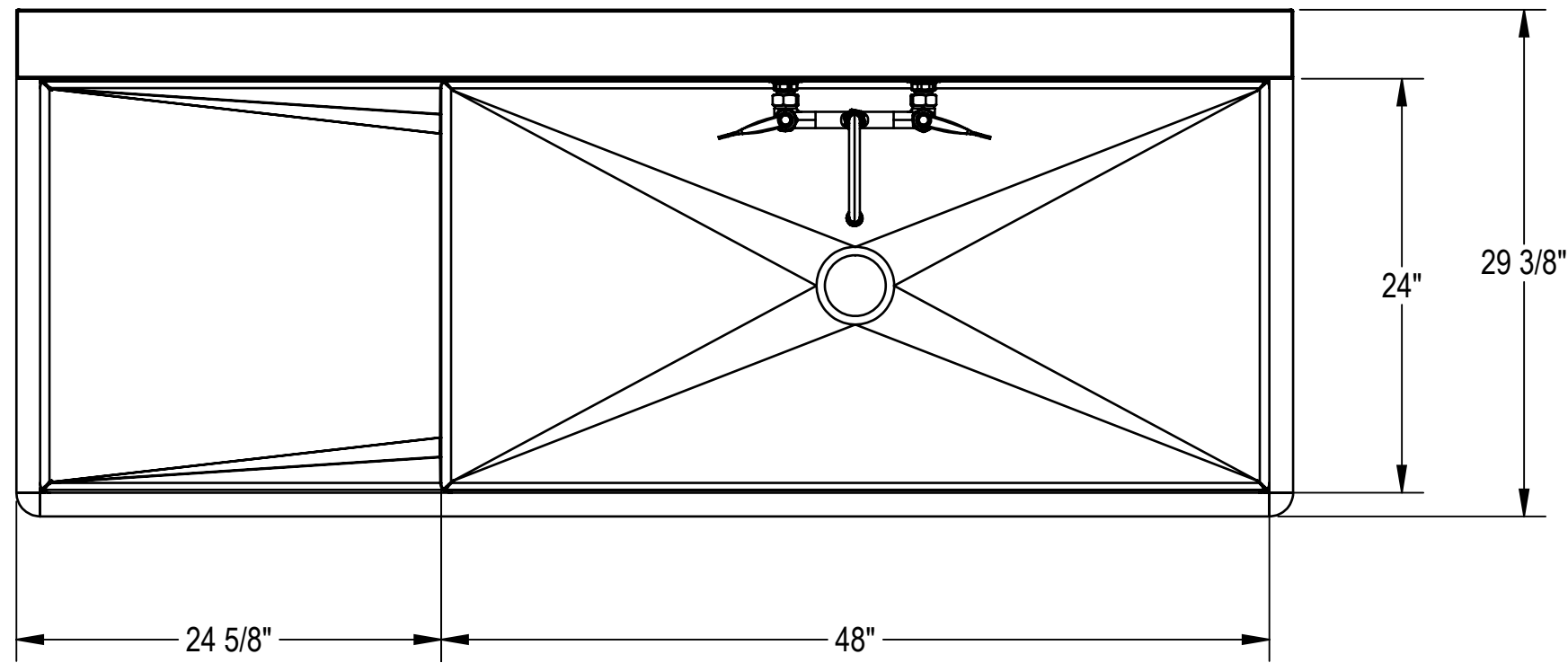

CUSTOMER		APPROVAL		<p style="text-align: center;">PROPRIETARY</p> <p style="text-align: center;">THIS DOCUMENT AND THE DATE DISCLOSED HEREIN AND HEREWITH IS NOT TO BE REPRODUCED, USED OR OTHERWISE DISCLOSED IN WHOLE OR IN PART TO ANYONE WITHOUT WRITTEN AUTHORIZATION FROM MORTECH MFG.</p>			 411 North Aerojet Avenue Azusa, CA 91702 tel: (800) 410-0100 (626) 334-1471 fax: (626) 334-1704 www.mortechmfg.com	
PROJECT		SIGNATURE					DATE	DO NOT SCALE DRAWING MATERIAL: 304 STAINLESS STEEL FINISH: #4
				SCALE: 1:8	SIZE: C	DWG NO.: MS2448L-24AP	REV. X01	SHEET 1 OF 3

UTILITY REQUIREMENT NOTES:

1. FLUSH LINES CLEAR BEFORE CONNECTING TO STATION.
2. PLUMBER TO PROVIDE SHUT-OFF VALVES FOR WATER CONNECTIONS AND P-TRAP FOR DRAIN.

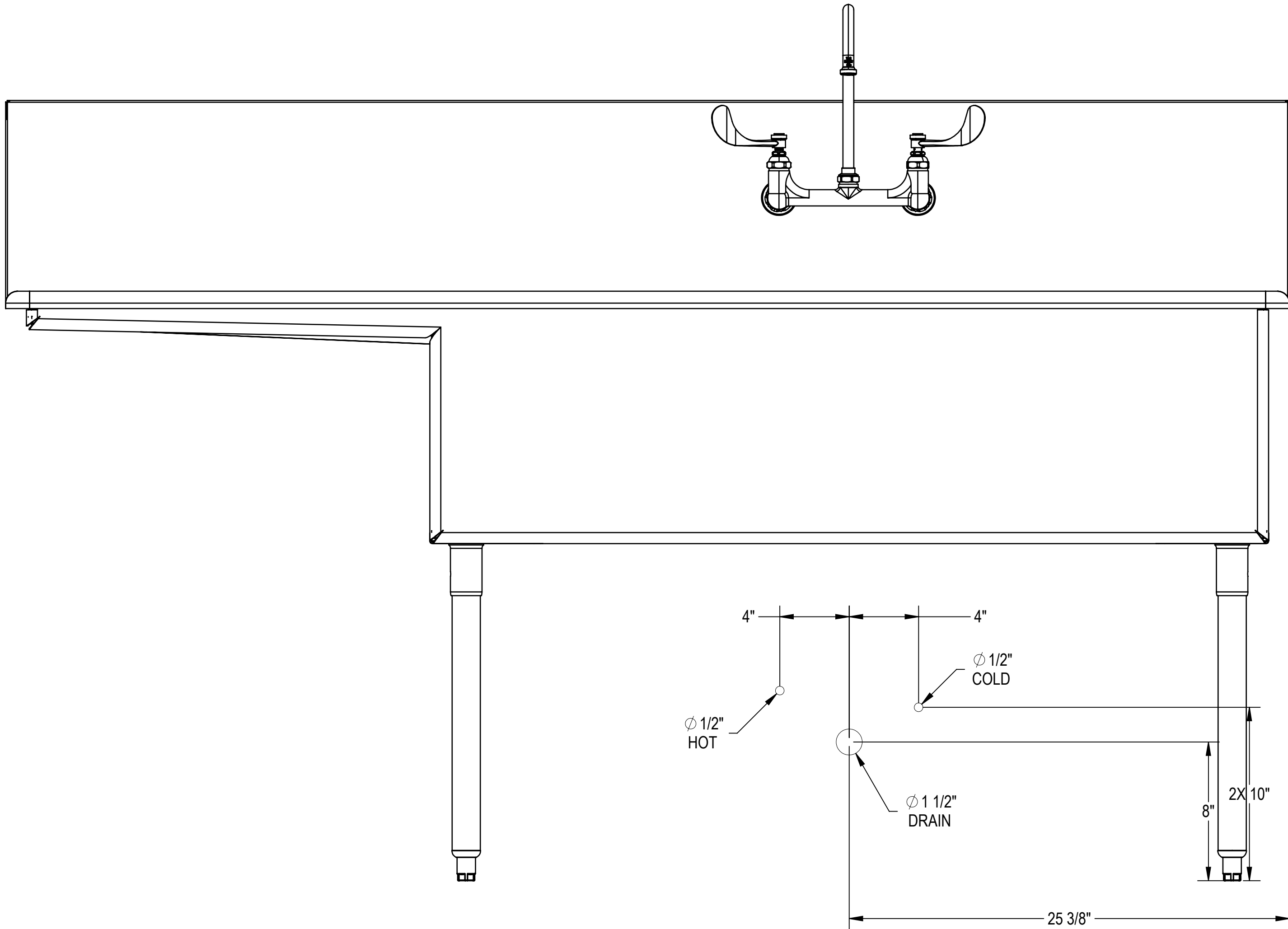

CUSTOMER		APPROVAL		<p style="text-align: center;">PROPRIETARY</p> <p style="text-align: center;">THIS DOCUMENT AND THE DATE DISCLOSED HEREIN AND HEREWITH IS NOT TO BE REPRODUCED, USED, OR OTHERWISE DISCLOSED IN WHOLE OR IN PART TO ANYONE WITHOUT WRITTEN AUTHORIZATION FROM MORTECH MFG.</p>					411 North Aerojet Avenue Azusa, CA 91702 tel: (800) 410-0100 (626) 334-1471 fax: (626) 334-1704 www.mortechmfg.com		
PROJECT		SIGNATURE					DATE		TITLE MODEL MS2448L-24		STAINLESS STEEL SCULLERY SINK, LEFT DRAINBOARD
						DO NOT SCALE DRAWING		APPROVALS DRAWN BY: D. FRADEJAS CHECKED BY:		DATE 06/21/24	
						MATERIAL 304 STAINLESS STEEL		FINISH #4		SIZE C	
						APPROVED BY:		SCALE 1:8		NEXT ASSY. SHEET 2 OF 3	
								DWG NO. MS2448L-24AP		REV. X01	

WALL MOUNTING NOTES:

1. Z-BAR SHIPPED WITHOUT MOUNTING HOLES FOR ADOPTION TO FIELD CONDITIONS. HOLES TO BE DRILLED BY INSTALLER.
2. INSTALL 7 ANCHORS AT 8 3/4" ON CENTER. FIRST HOLE: 1" IN FROM SIDE OF Z-BAR. Z-BAR LENGTH: 52" LONG. ADDITIONAL ANCHORS CAN BE ADDED AS NEEDED.
3. USE MINIMUM 1/4" TEK SCREWS 2 3/4" LONG. ADJUST LENGTH PER WALL THICKNESS.
4. ANCHORS USED MUST BE FLUSH TO Z-BAR AS MUCH AS POSSIBLE. THEY MUST NOT INTERFERE WITH PLUMBING BEHIND WALL.
5. INSTALLATION IS BASED ON ROUGH-IN MOUNTING DETAIL PROVIDED.

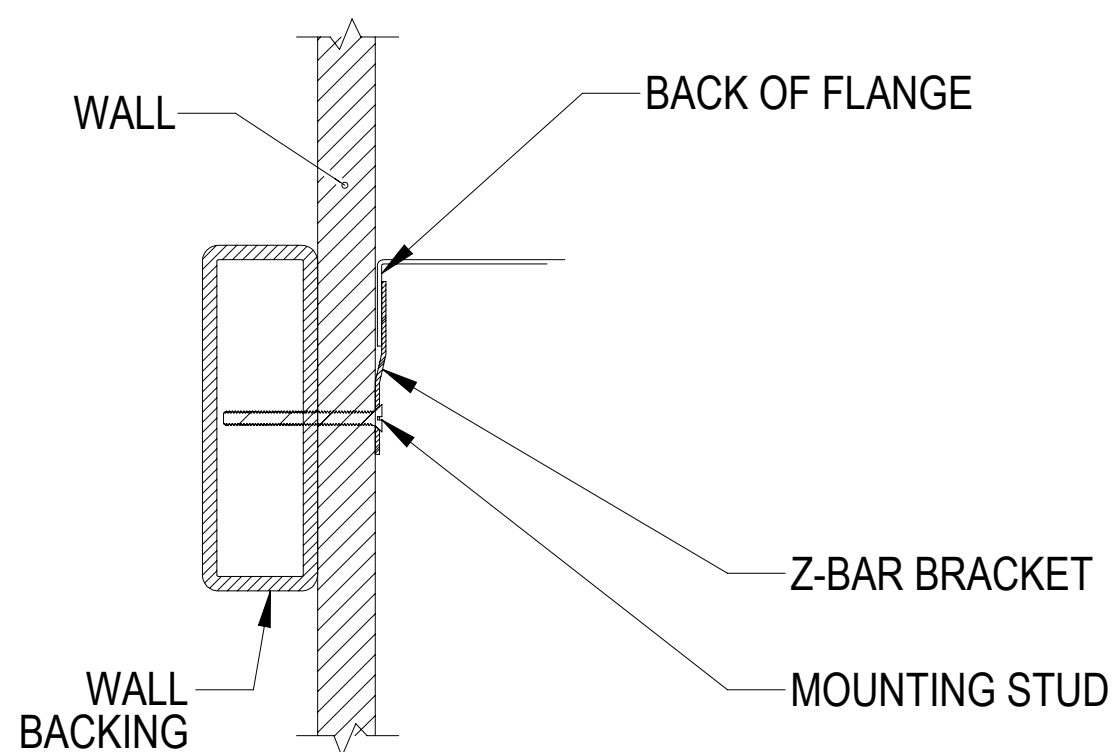
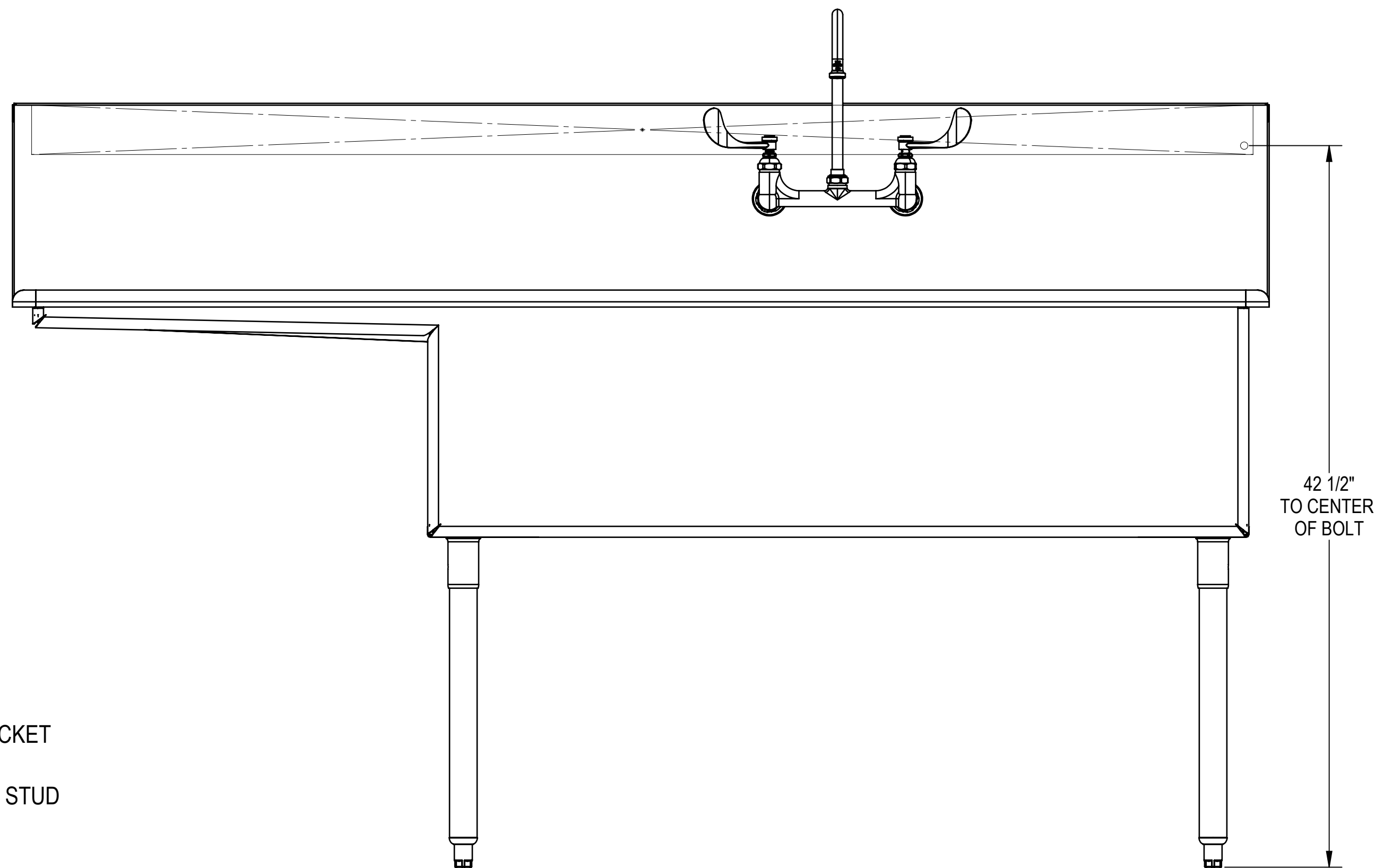

SECTION A-A
SCALE 1 : 4

CUSTOMER		APPROVAL		<p style="text-align: center;">PROPRIETARY</p> <p style="text-align: center;">THIS DOCUMENT AND THE DATE DISCLOSED HEREIN AND HEREWITH IS NOT TO BE REPRODUCED, USED, OR OTHERWISE DISCLOSED IN WHOLE OR IN PART TO ANYONE WITHOUT WRITTEN AUTHORIZATION FROM MORTECH MFG.</p>			<p style="text-align: center;">MOPEC GROUP</p> <p style="text-align: center;">411 North Aerojet Avenue Azusa, CA 91702 tel: (800) 410-0100 (626) 334-1471 fax: (626) 334-1704 www.mortechmfg.com</p>		
PROJECT		SIGNATURE							DATE
				DO NOT SCALE DRAWING		APPROVALS		DATE	
				MATERIAL		DRAWN BY		DWG NO.	
				304 STAINLESS STEEL		D. FRADEJAS		06/21/24	
				FINISH		CHECKED BY		REV.	
				#4		APPROVED BY		MS2448L-24AP	
								X01	
						SCALE 1:8		NEXT ASSY.	
								SHEET 3 OF 3	