

NOTES: UNLESS OTHERWISE SPECIFIED

1. APPLICABLE STANDARDS AND SPECIFICATIONS;
ASME Y14.5-2009, DIMENSIONING AND TOLERANCING
ASME Y14.5-2007, ABBREVIATIONS

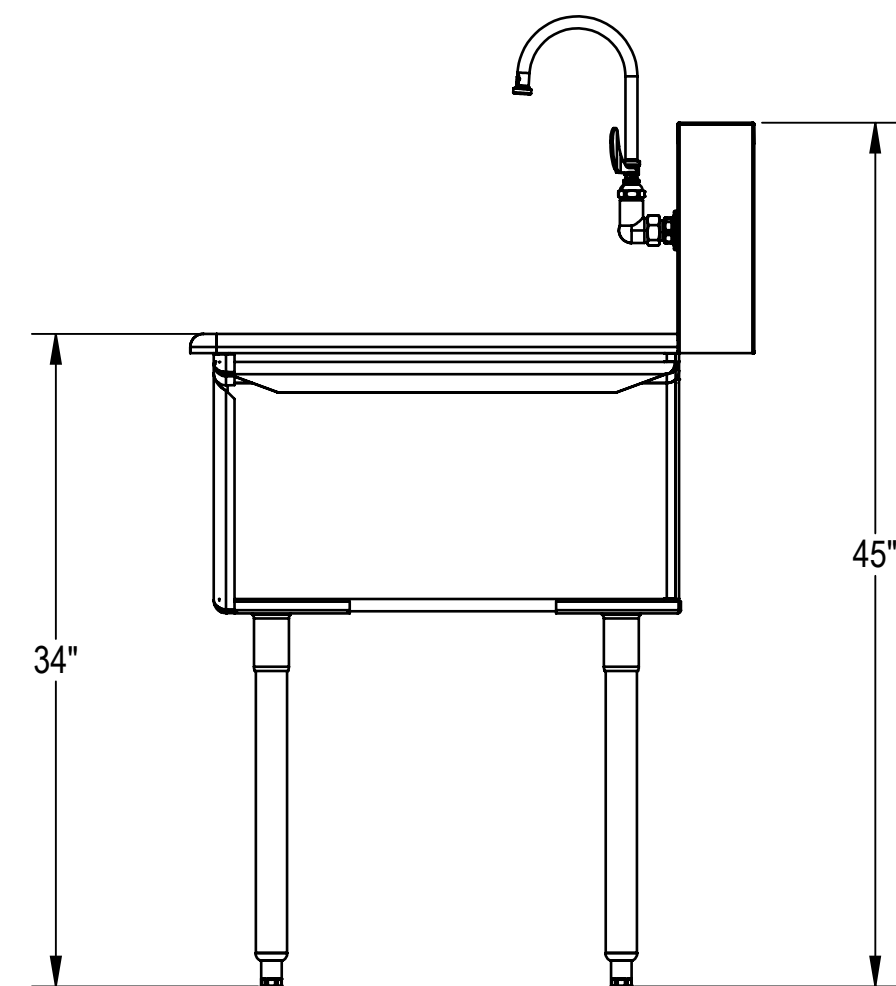
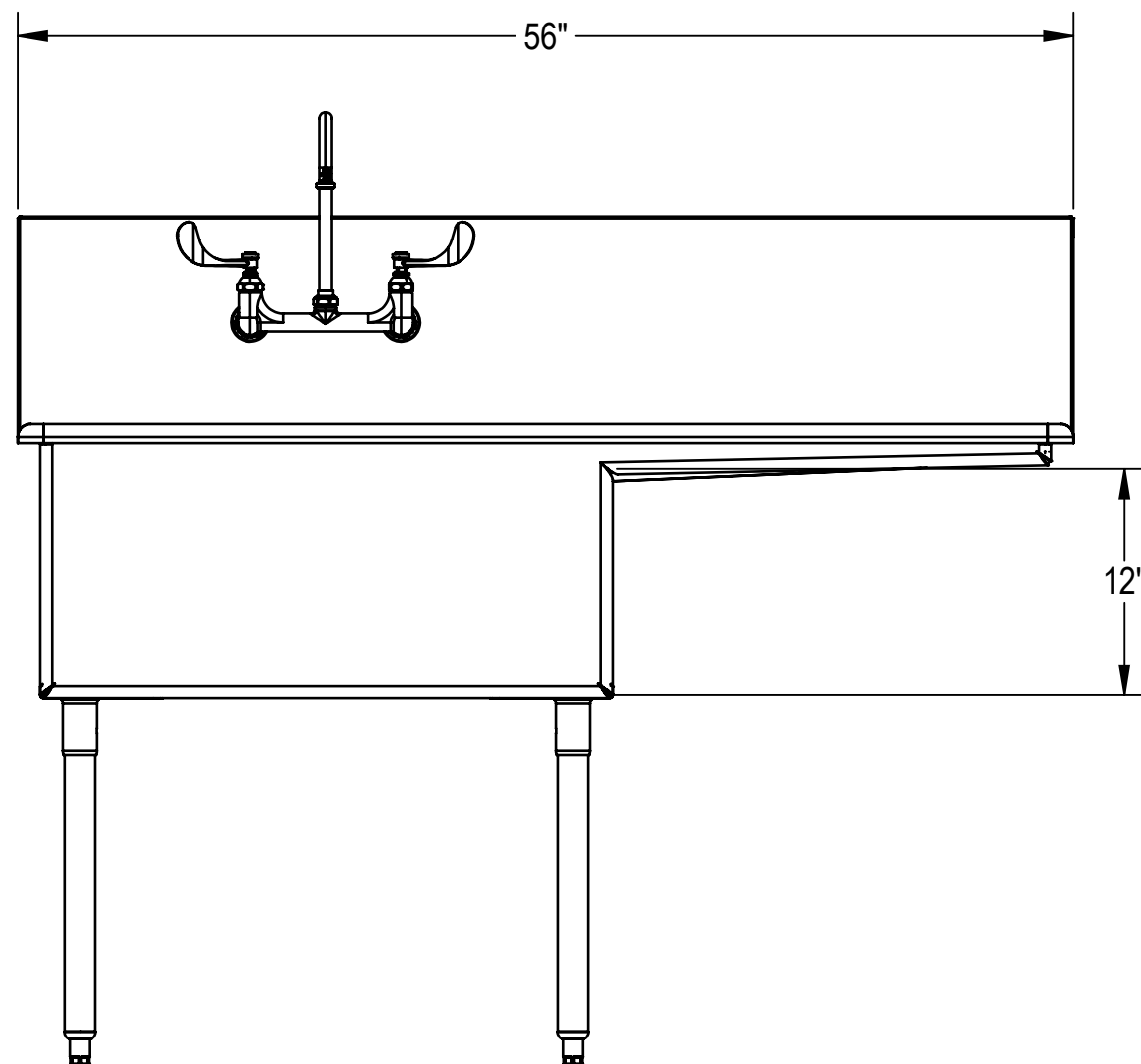
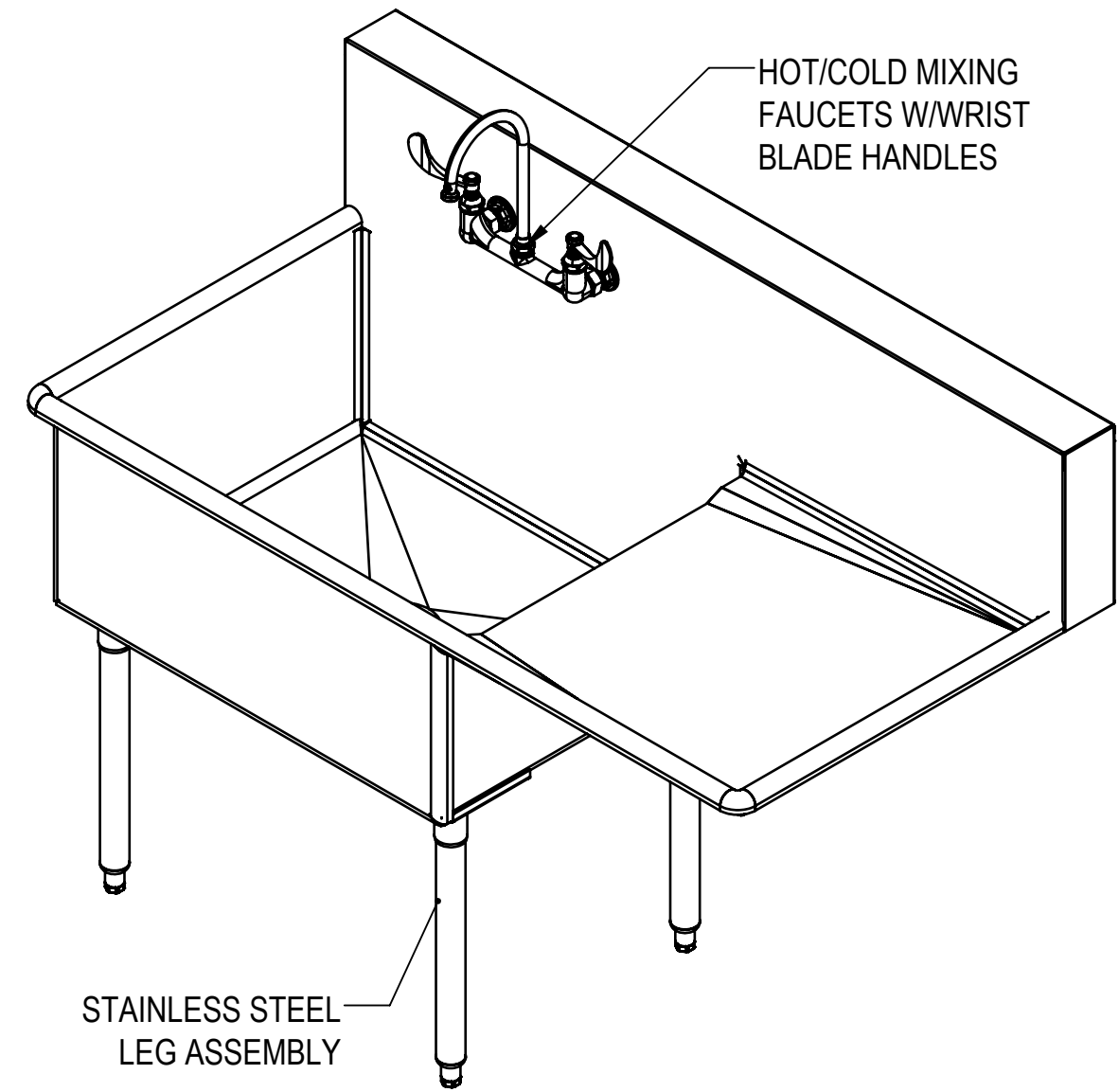
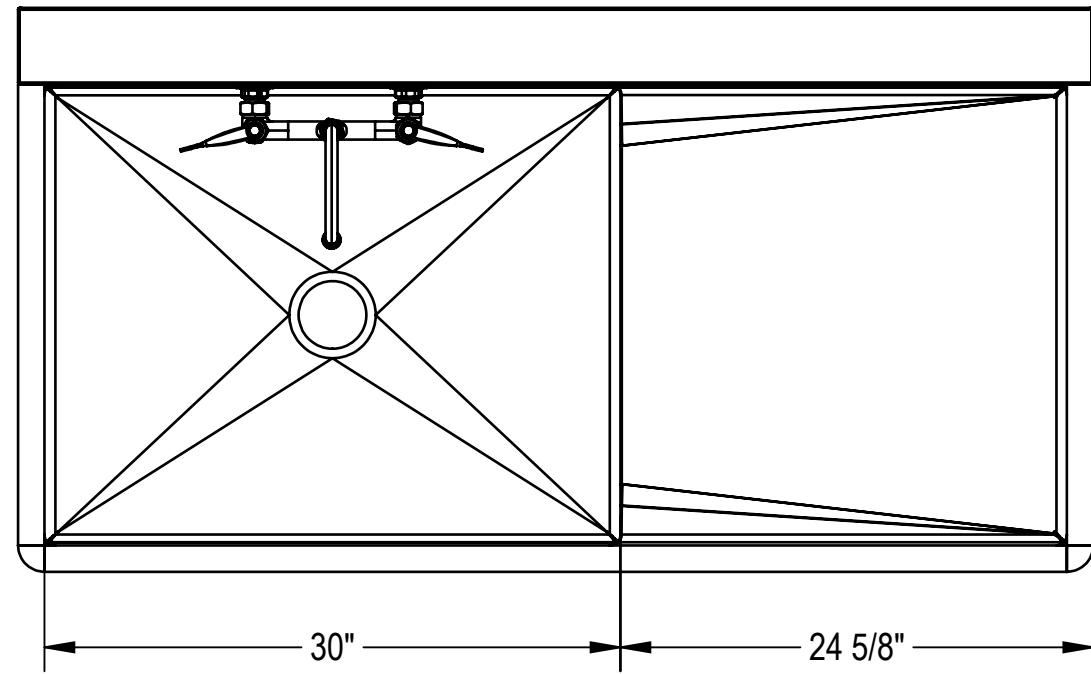

| | | | | | | | | | | |
|----------|--|-----------|--|--|---------------------|-------------|---|--|---|--------------|
| CUSTOMER | | APPROVAL | | <p style="text-align: center;">PROPRIETARY</p> <p style="text-align: center;">THIS DOCUMENT AND THE DATE DISCLOSED HEREIN AND HEREWITH IS NOT TO BE REPRODUCED, USED OR OTHERWISE DISCLOSED IN WHOLE OR IN PART TO ANYONE WITHOUT WRITTEN AUTHORIZATION FROM MORTECH MFG.</p> | | | MOPEC GROUP MORTECH ISO 9001:2015 CERTIFIED COMPANY | | 411 North Aerojet Avenue Azusa, CA 91702 tel: (800) 410-0100 (626) 334-1471 fax: (626) 334-1704 www.motechmfg.com | |
| PROJECT | | SIGNATURE | | | | | DATE | DO NOT SCALE DRAWING | APPROVALS | DATE |
| | | | | | MATERIAL | CHECKED BY | | MODEL MS2430R-24 STAINLESS STEEL SCULLERY SINK, RIGHT DRAINBOARD | DWG NO. | |
| | | | | | 304 STAINLESS STEEL | D. FRADEJAS | 06/21/24 | MS2430R-24AP X01 | SCALE | |
| | | | | | FINISH | APPROVED BY | | 1:8 | NEXT ASSY. | SHEET 1 OF 3 |
| | | | | | #4 | | | | | |

UTILITY REQUIREMENT NOTES:

1. FLUSH LINES CLEAR BEFORE CONNECTING TO STATION.
2. PLUMBER TO PROVIDE SHUT-OFF VALVES FOR WATER CONNECTIONS AND P-TRAP FOR DRAIN.

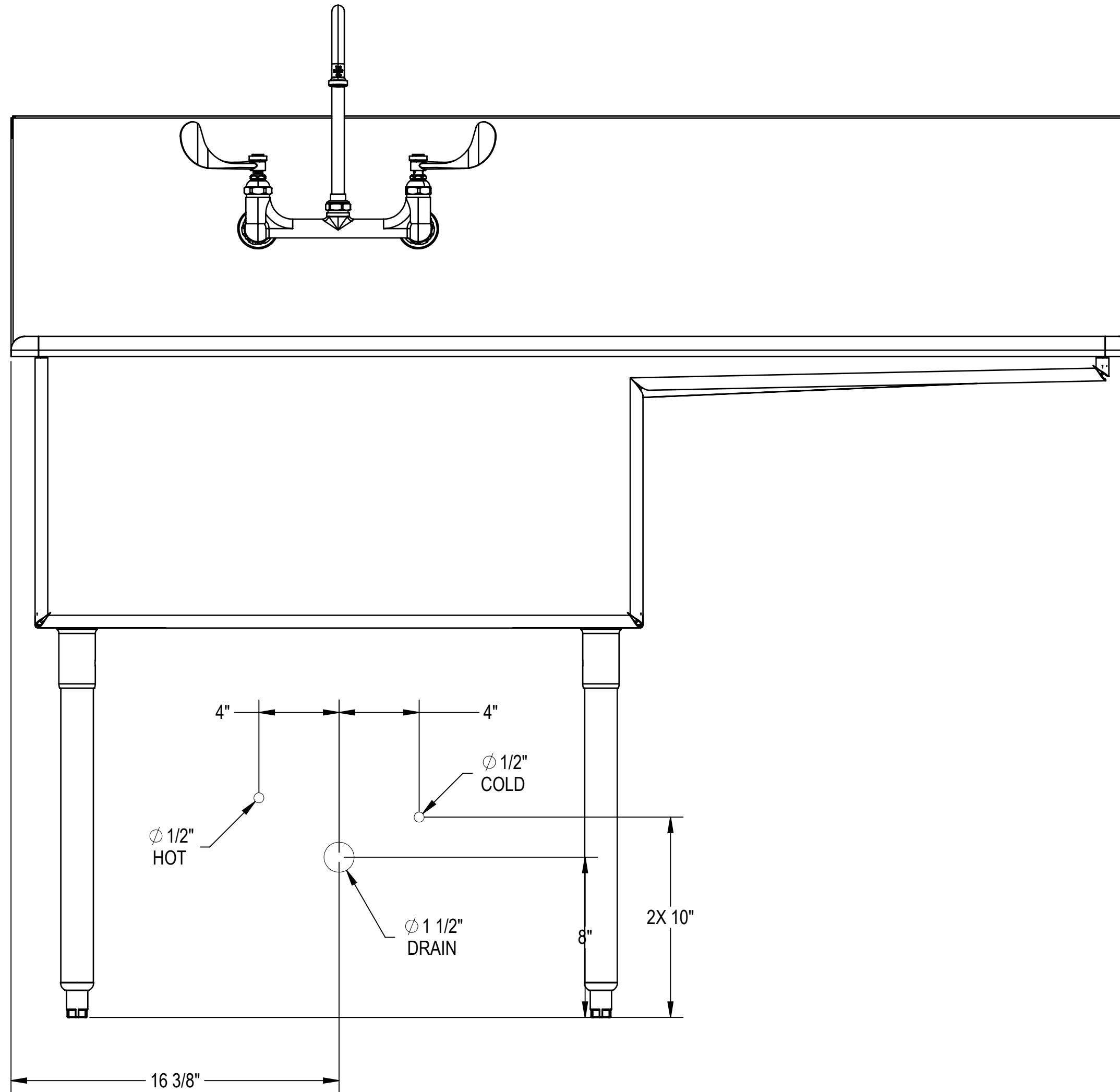

| | | | | | | | | | | | |
|----------|--|-----------|--|---|--|--|---|-------------------------|--|------------|---|
| CUSTOMER | | APPROVAL | | <p style="text-align: center;">PROPRIETARY</p> <p style="text-align: center;">THIS DOCUMENT AND THE DATE DISCLOSED HEREIN AND HEREWITH IS NOT TO BE REPRODUCED, USED, OR OTHERWISE DISCLOSED IN WHOLE OR IN PART TO ANYONE WITHOUT WRITTEN AUTHORIZATION FROM MORTECH MFG.</p> | | |  | | 411 North Aerojet Avenue Azusa, CA 91702 tel: (800) 410-0100 (626) 334-1471 fax: (626) 334-1704 www.mortechmfg.com | | |
| PROJECT | | SIGNATURE | | | | | DATE | | MODEL MS2430R-24 | | TITLE STAINLESS STEEL SCULLERY SINK, RIGHT DRAINBOARD |
| | | | | | | DO NOT SCALE DRAWING | | APPROVALS | | DATE | |
| | | | | | | MATERIAL 304 STAINLESS STEEL | | DRAWN BY D. FRADEJAS | | 06/21/24 | |
| | | | | | | FINISH #4 | | CHECKED BY | | REV. X01 | |
| | | | | | | APPROVED BY | | SCALE 1:8 | | NEXT ASSY. | |
| | | | | | | | | SHEET 2 OF 3 | | | |

WALL MOUNTING NOTES:

1. Z-BAR SHIPPED WITHOUT MOUNTING HOLES FOR ADOPTION TO FIELD CONDITIONS. HOLES TO BE DRILLED BY INSTALLER.
2. INSTALL 7 ANCHORS AT 8 3/4" ON CENTER. FIRST HOLE: 1" IN FROM SIDE OF Z-BAR. Z-BAR LENGTH: 52" LONG. ADDITIONAL ANCHORS CAN BE ADDED AS NEEDED.
3. USE MINIMUM 1/4" TEK SCREWS 2 3/4" LONG. ADJUST LENGTH PER WALL THICKNESS.
4. ANCHORS USED MUST BE FLUSH TO Z-BAR AS MUCH AS POSSIBLE. THEY MUST NOT INTERFERE WITH PLUMBING BEHIND WALL.
5. INSTALLATION IS BASED ON ROUGH-IN MOUNTING DETAIL PROVIDED.

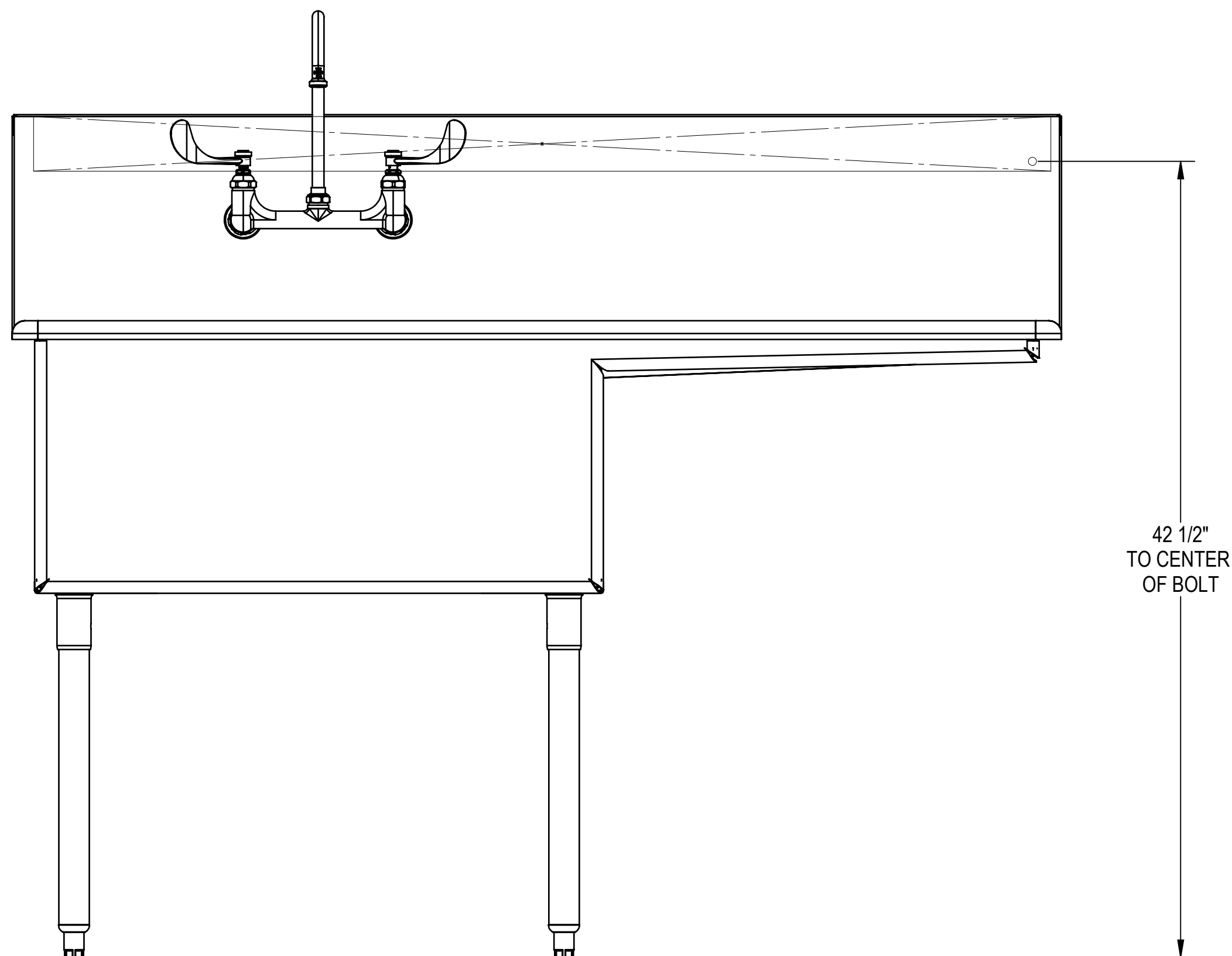
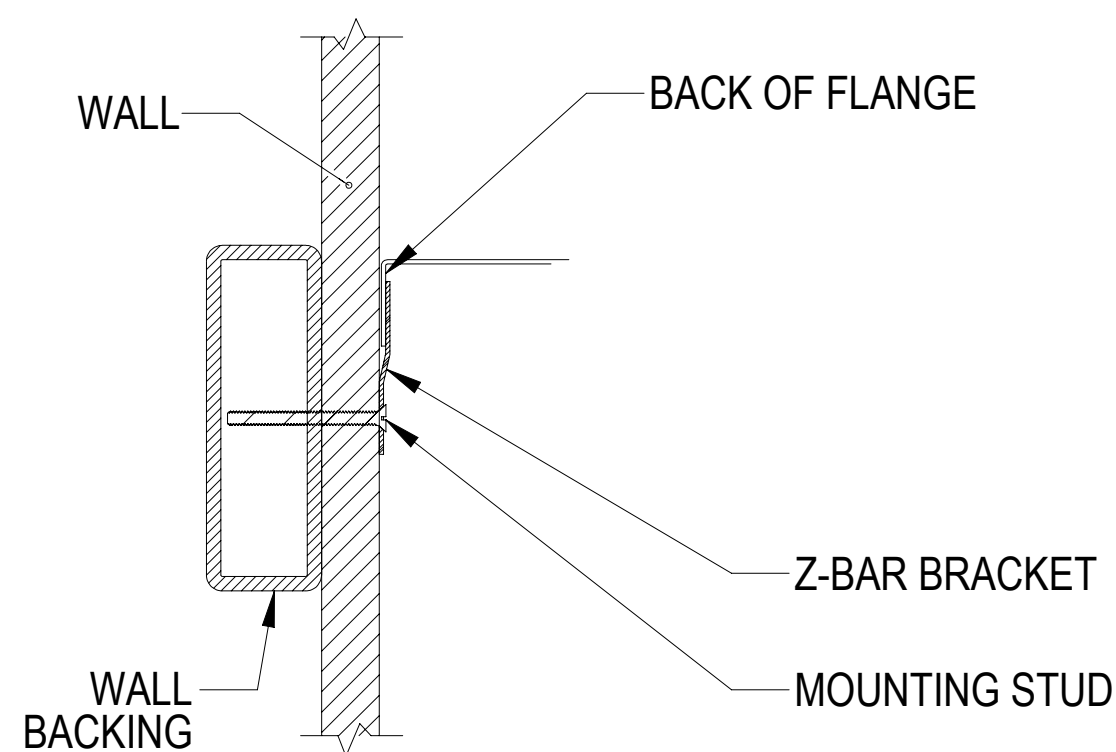

| | | | | | |
|----------|-----------|---|----------------------|--------------|---|
| CUSTOMER | APPROVAL | PROPRIETARY | | |  411 North Aerojet Avenue Azusa, CA 91702 tel: (800) 410-0100 (626) 334-1471 fax: (626) 334-1704 www.mortechmfg.com |
| | | THIS DOCUMENT AND THE DATE DISCLOSED HEREIN AND HEREWITH IS NOT TO BE REPRODUCED, USED, OR OTHERWISE DISCLOSED IN WHOLE OR IN PART TO ANYONE WITHOUT WRITTEN AUTHORIZATION FROM MORTECH MFG. | | | |
| PROJECT | SIGNATURE | DATE | DO NOT SCALE DRAWING | APPROVALS | DATE |
| | | | MATERIAL | DRAWN BY | CHECKED BY |
| | | | 304 STAINLESS STEEL | D. FRADEJAS | 06/21/24 |
| | | | FINISH | APPROVED BY | |
| | | | #4 | | |
| | | | SIZE | DWG NO. | REV. |
| | | | C | MS2430R-24AP | X01 |
| | | | SCALE | NEXT ASSY. | SHEET |
| | | | 1:8 | | 3 OF 3 |