

NOTES: UNLESS OTHERWISE SPECIFIED

1. APPLICABLE STANDARDS AND SPECIFICATIONS;
ANSI Y14.5M, DIMENSIONS AND TOLERANCES
ANSI Y1.1, ABBREVIATIONS

| REVISIONS | | | | |
|-----------|------|--------------------|----------|------------------|
| REV. | DCN# | DESCRIPTION | DATE | CHANGED/APPROVED |
| A | - | PRODUCTION RELEASE | 10/24/12 | PV/RR |

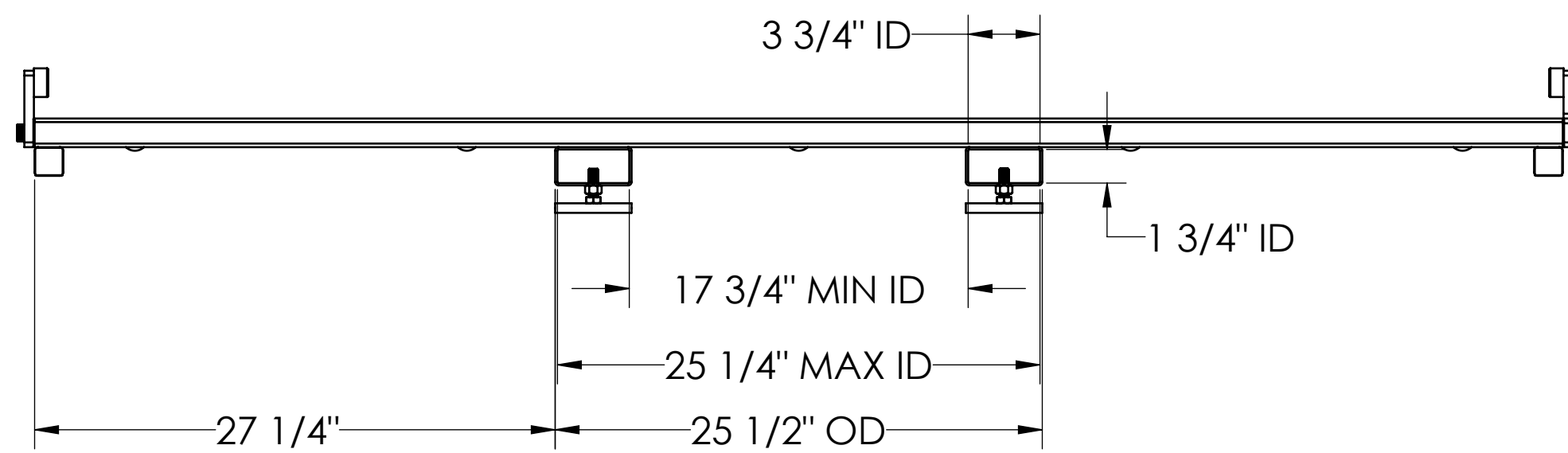
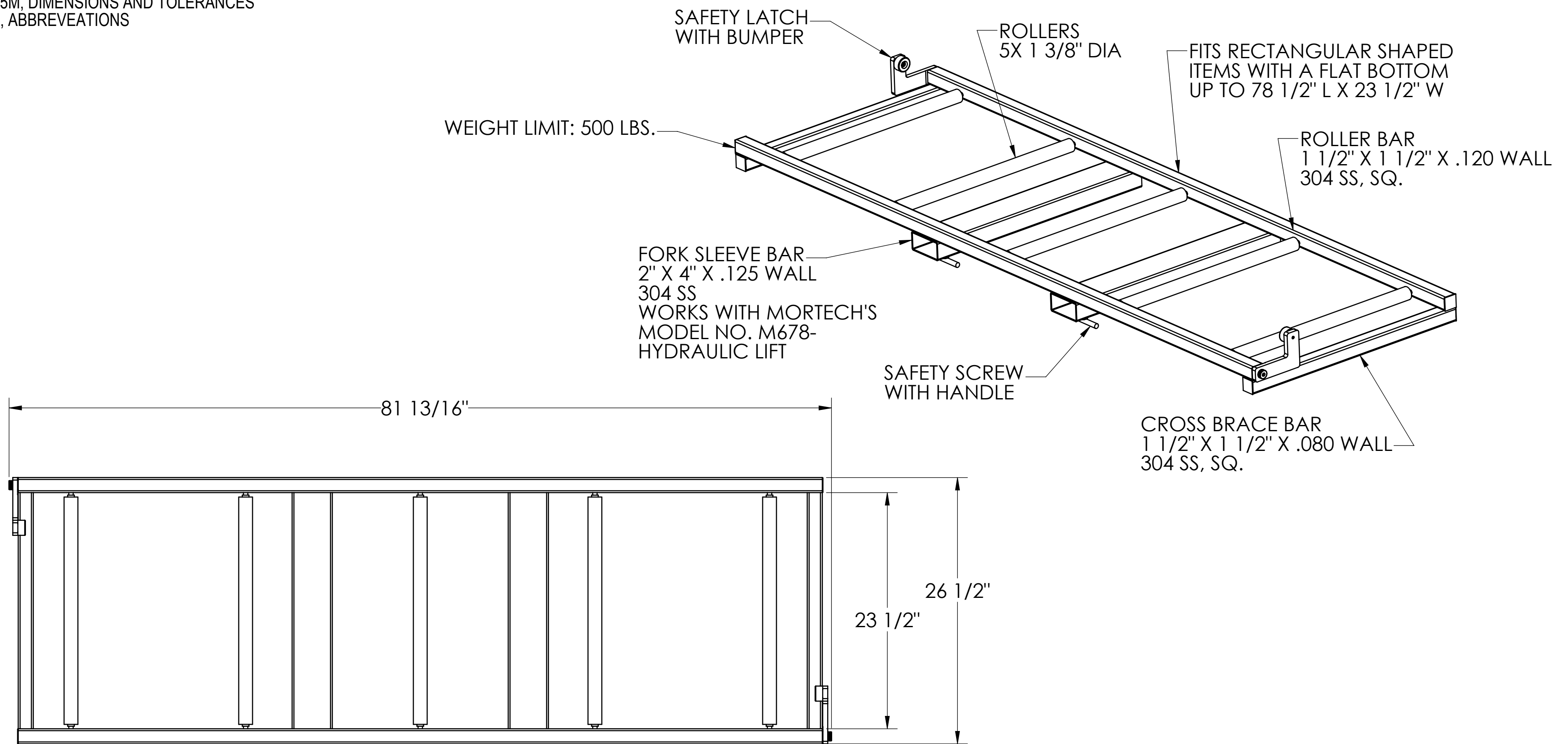

| | | | | | | | | | |
|----------------------------------|--|-----------|--|--|--|---|--|--|--|
| CUSTOMER CUSTOMER NAME | | APPROVAL | | TOLERANCE BLOCK: DIMENSIONS ARE IN INCHES | | PROPRIETARY THIS DOCUMENT AND THE DATE DISCLOSED HEREIN AND HERewith IS NOT TO BE REPRODUCED, USED, OR OTHERWISE DISCLOSED IN WHOLE OR IN PART TO ANYONE WITHOUT WRITTEN AUTHORIZATION FROM MORTECH MFG. | | 411 North Aerojet Avenue Azusa, CA 91702 tel: (800) 410-0100 (626) 334-1471 fax: (626) 334-1704 www.mortechmfg.com | |
| PROJECT PROJECT NAME | | SIGNATURE | | DECIMALS .X ± .1 ANGLES ± 1° DECIMALS .XX ± .01 FRACTIONS ± 1/16" DECIMALS .XXX ± .005 | | APPROVALS DATE DRAWN BY: PETE V. 03/06/12 CHECKED BY: RICK R. 10/29/12 APPROVED BY: GINO J. 10/29/12 | | ISO 9001: 2008 CERTIFIED COMPANY MODEL M601H- FULL ROLLER PALLET ASSEMBLY, 23" HYD | |
| | | DATE | | DO NOT SCALE DRAWING | | MATERIAL 304 STAINLESS STEEL | | TITLE: M601HAP SIZE: C DWG NO.: SCALE: 1:8 NEXT ASSY.: SHEET 1 OF 1 | |
| | | | | FINISH GRAINED | | APPROVED BY: GINO J. 10/29/12 | | REV: A | |