

Morgue Refrigerator (2 Body), Roll-In - KB1500

Drop-in self-contained refrigeration system with digital thermometer and easy to adjust temperature controller. Heavy-duty chrome plated hardware for long lasting use. Unit ships fully assembled - simply plug unit into an outlet and the unit is operational.

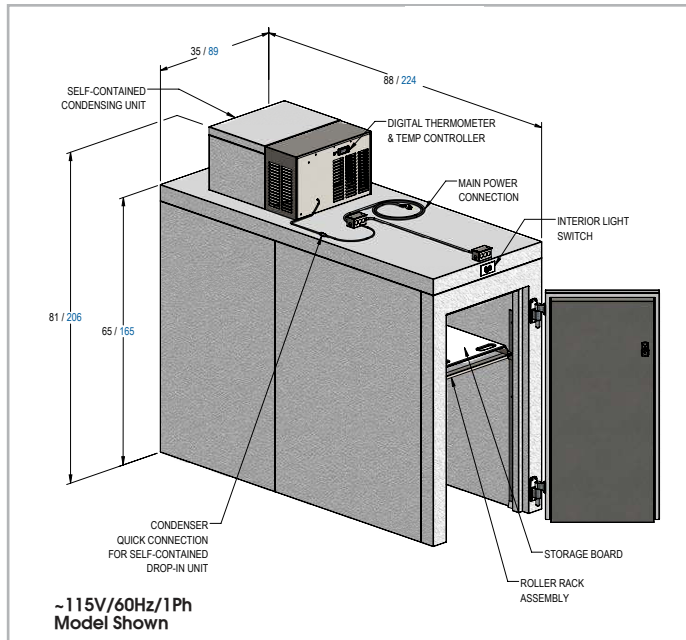

SPECIFICATIONS

Construction

- Front Exterior: .032" Type 304 stainless steel with a No. 4 finish
- Top, sides, and back exterior: .040" stucco embossed aluminum
- Interior: Stucco embossed galvanized
- Insulation: 4" foamed in place urethane
- Provided with (1) interior roller racks
- Overlap door with magnetic gasket

Materials

- Stainless steel and stucco embossed aluminum exterior
- Heavy-duty chrome-plated hardware for long lasting use
- (1) HD plastic storage boards

Dimensions

- Overall: 35" W x 88" D x 81" H
- Doors: 24" W x 54" H

Utilities / Power

- 115V / 60Hz / 1 Ph
- 208-230V / 50-60Hz / 1 Ph available (may affect dimensions & features)

Controls

- Vapor proof light with switch

Performance

- Drop-in self-contained refrigeration system with digital thermometer and easy to adjust temperature controller
- Operating Temperature: 38°F / 3.3°C

Installation

- Unit ships fully assembled, simply plug unit into an outlet and the unit is operational

Options & Accessories

- Custom sizes for larger cases
- Stainless steel body trays
- Mortuary cot or carrier



www.mopec.com

800.362.8491

800 Tech Row

Madison Heights, MI 48071