

DD SERIES

Body Tray Saddle Autopsy Cart



REFERENCE MANUAL



21750 Coolidge Highway • Oak Park, MI 48237 USA
+1 800-362-8491 • 248-291-2040 • Email: info@mopec.com

Rev 6-4-16 ©

IMPORTANT INFORMATION

MODEL NO.:

SERIAL NO.:

DATE OF PURCHASE:

DATE OF INSTALLATION:

INSTALLATION NOTES:

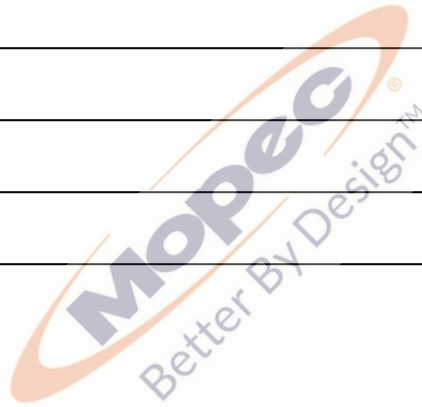

SERVICE AND SUPPORT:



21750 Coolidge Highway • Oak Park, MI 48237 USA
+1 800-362-8491 • 248-291-2040 • Email: info@mopec.com

TABLE OF CONTENTS

INTRODUCTION	4
CUSTOMER AND TECHNICAL SUPPORT	5
UNPACKING	6
CLEANING AND MAINTENANCE	7
STANDARD FEATURES	11
WARRANTY	12
ISO CERTIFICATE	13
UNIT DRAWINGS	
DD000	14
DD050	15
DD100	16
DD200	17



INTRODUCTION

Fitted to saddle the JC Series Body Tray within the frame, the DD Series is designed with a built in slope.

Body trays are removable and easily transported with a motorized or manual fork type lift.

All Mopec carts feature Total Lock caster system with non corrosive, 8" heavy-duty wheels. Caster wheel center is fabricated using state-of-the-art polyimide plastic with polyurethane treads for years of lasting service. Steering and braking are accomplished through an effortless step motion.

During transport, the steer caster can be locked for easy mobility.

- DD000 AUTOPSY CART TRAY SADDLE (23" Tray CHASSIS)
- DD050 AUTOPSY CART TRAY SADDLE (27" Tray CHASSIS)
- DD100 AUTOPSY CART TRAY SADDLE (W/JC100)
- DD200 AUTOPSY CART TRAY SADDLE (W/JC101)

CUSTOMER AND TECHNICAL SUPPORT

All Mopec staff members are Customer Service experts. We believe in providing nothing but the best possible service for all our customers. Our Technical Support group includes everyone from our design engineers to members of our production group. All are dedicated to providing comprehensive and courteous support to all Mopec customers.

The following information is included to help our customers communicate with Customer and Technical Support at Mopec.

Mopec

21750 COOLIDGE HWY.
OAK PARK , MICHIGAN 48237
TOLL FREE 800.362.8491
248.291.2040 PH. 248.291.2050 FX



UNPACKING

- 1.) Carefully inspect the exterior of the shipping container before opening. If the crate is damaged and the product has sustained damage then immediately contact Mopec and the freight carrier. **Never discard the shipping container even if it is damaged beyond recognition.**
- 2.) Have the receiver note any suspected damage on the bill of lading and sign it. Mopec will help assist in filing a claim for product repair and/or replacement.
- 3.) Carefully open the containers and inspect the goods for concealed damage. If concealed damage is noticed (i.e. Broken welds, dented stainless, scratches, etc.) Follow through as noted above, and again do not discard the shipping material, they are important in settling claims.



CLEANING AND MAINTENANCE

DISINFECTING AND MAINTAINING STAINLESS STEEL SURFACES

All stainless steel surfaces can be cleaned with soap and water, which will remove debris.

The stainless steel surfaces can be disinfected with a non caustic disinfectant. We suggest using BE045 Path Cloud or BE047 Bench Wipe for cleaning purposes. We recommend you **DO NOT USE** a bleach solution to clean your unit, bleach will eventually erode stainless steel if not thoroughly rinsed. **The use of chlorine bleach will VOID THE STAINLESS STEEL WARRANTY**

To maintain your stainless steel product, follow these four steps:

1) Never, ever use wire brushes, Brillo, steel wool or abrasive cleansers (like Ajax or Comet). If something needs to be aggressively cleaned only use a Scotch-brite pad or similar product and only scour with the "grain" of the stainless. As an example, please reference the photo on page 2 of this document. It is clear that a very abrasive product was used in an area on the unit and that did not follow the grain of the stainless. The effects of this scratching may diminish over time with proper care but the effects of this scouring are obvious. (The use of the Scotch-brite Pad following the grain over time may help scratches such as this). Depending on the surface finish of your stainless steel, abrasive cleaners can cause scratching. Duller finishes probably won't show scratching as much as mirror or highly polished finishes. When in doubt, test in a hidden spot, and also work from the least risky type of cleaning, (i.e. water) to the heavy duty stuff.

Do not use cleaners containing chlorine. While it may be second nature to bleach everything, stainless steel and chlorine do not mix well. Do not use bleach when cleaning stainless steel. Do not allow bleach or bleach water to sit for long periods. Bleach can eventually cause staining and pitting. Bleach stains are removed with stainless steel cleaning polish.

2) Keep the surface clean of grime, tissue and particulates. This can be accomplished by using the "Water Hand Spray Rinse" and use of cleaning products.

3) Rinse the surface after using disinfectant. In Pathology and other medical areas the act of disinfecting is desired. There are a number of ways to do this including using Mopec's Bench Spray & Wipe Disinfectant. Labs use any number of different products including 10% bleach or other disinfectant sprays and wipes. For the most part, each and every one of these has high salt contents and lower PH levels to aid with disinfection. Most disinfectants must be followed up with a water rinse to remove the salts that remain after these products dry. We advise to always follow up a disinfection cleaning with a thorough rinse of water. We advise not to use diluted bleach, if you must; we stress the importance of a

thorough rinse of water after use. If not rinsed properly, these salts can become visible after the disinfectant dries. They can appear with a whitish characteristic or contain light lines of white with a grainy feel when you wipe your hand across the work surface. If these residues are not removed with a thorough water rinse and wipe down they will accumulate and eventually degrade the appearance and integrity of your stainless surface. Rust is a long term possibility if salts are allowed to remain on the work surfaces over time. Gritty, dirty water or residue from cleaning solutions left on a stainless steel surface can stain or damage the finish.

4) **All stainless steel products should be protected by a polish.** As a prime example before any product leaves Mopec it is coated with WD-40 as a protecting coating for the stainless. Mopec offers a Stainless Steel Cleaner and Polish in both wipe and spray. These Mopec products will not only deep clean your stainless but will also protect their finish from chemical, low PH and salt and keep the finish looking like new.

Decal

Mopec advises that if the technicians are not taking the proper precautions when using the Decal solution the possibility of two things will occur, a brown or rust ring where the Decal resides along with a milky white substance on the surface. (As an example, reference the below photos to see the rust rings.) Decal is very harsh, even the fumes can and will cause staining on stainless steel. One thing that you might want to consider doing is to place the Decal container you currently use inside a plastic base that will help catch drips that might occur. Clean and rinse your station after every use of Decal solution.

Rust

Rust can and will occur on stainless if it is not maintained properly. The most common cause of rust is from using metal or stainless racks that are not made of 304 stainless. This is referred to as "transfer rust". Leaving of salts from cleaners or disinfectants can and will lead to possible rust areas in the long term. Always rinse all disinfectants before they dry. Decal solutions and even fumes are very aggressive and can cause rust if not cleaned up and used properly around stainless. Formalin use has not been shown to cause rust in any way.



Conclusions & Suggestions

We are confident and can assure you that if you institute the suggestions detailed above that your Mopec Grossing station will look as it did the day it arrived.

Do not assume it's the cleaner. If you do have some spotting or staining, and you've followed all of the suggestions, it may not be the cleaner. Water, especially hard water, can leave spotting and staining on stainless steel surfaces. Hard water can leave mineral deposits, resulting in whitish-colored spots and streaks. Remove hard water stains with vinegar or with stainless steel cleaning polish. Prevent hard water stains by towel-drying after every wash.

Do not allow soaps and cleaners to dry on surfaces. The chemicals in many soaps and cleaners can cause staining. Never use corrosive cleaners such as mineral spirits. Use stainless steel cleaning polish and a non-abrasive scrub pad to remove dried cleaner stains. Baking soda mixed with liquid dish soap can make a good paste to gently rub on stains. Be sure to rinse the stainless steel surface thoroughly, and towel dry.

If stains remain Mopec recommends trying a stainless steel cleaner and polisher. Barkeeper's Friend is a good powder formula that can clean without scratching. Be sure to follow the directions, rinse thoroughly, and towel dry. These methods should help remove any discoloration.

Fingerprints and Stains – The most common surface contaminates that occur from normal use are fingerprints and mild stains. These usually affect only appearance so fortunately they do not have an effect on corrosion resistance. They can easily be removed by a variety of simple cleaning methods. The most troublesome marks to remove from the surface of smooth polished or bright finished stainless steel are fingerprints; fortunately they can be removed with a common glass cleaner or by gently rubbing with a paste of soda ash (sodium carbonate) and water which would be applied with a soft cloth. Again, it is best to follow with a warm water rinse.

Clean Water and Wipe – The method that will do an adequate job and is the simplest, safest and the least costly is the best method. There is no surface coating to wear off of stainless steels so the surface will thrive with frequent cleaning. The first choice to clean mild stains and loose dirt and soil should always be a soft cloth and clean, warm water. Rinsing with clean water and wiping the surface dry will finish the process and eliminate the possibility of water stains.

Solvent Cleaning – To remove oils, greases and fresh fingerprints that have not had time to oxidize or decompose, use a solvent that does not contain chlorine. There are many organic cleaners on the market today that optimize safety attributes and clean ability. Spray or vapor methods or by wiping with clothes containing solvents can also clean surfaces. The wiping technique will sometimes leave the surface streaked.

Scratch Repair

A surface scratch can be repaired using the following technique. Completely removing the scratch will depend on how severe it is.

Use 120 grit emery cloth or paper and firm pressure to sand the scratch. Sanding must always go in the direction of the grain. Sand in a perfectly straight line, avoiding the natural tendency to sand in an arc. Sand the surface until the scratch is gone.

Polish using a very fine grade of 3M scotch-brite pads. Use the same motions as with sanding. Polish the surface until the original finish is restored.

For stubborn spots, stains, light discoloration, water marking or light rust staining use a mild, non-scratching cream or polish. Apply with soft cloth or soft sponge and rinse off residues with clean water and dry. Avoid cleaning pastes with abrasive additions. Suitable cream cleansers are available with soft calcium carbonate additions, or with the addition of citric acid. Do not use chloride or acidic solutions



Nylon abrasive pads should be adequate for dealing with most deposits (DO NOT USE STEEL WOOL OR BRILLO PADS). If a more severe treatment is needed to mask coarse scratches or physical damage on a surface, use the finest abrasive medium consistent with covering the damage marks. With directional brushed and polished finishes, align and blend the new "scratch pattern" with the original finish, checking that the resulting finish is aesthetically acceptable. Silicon carbide media may be used, especially for the final stages of finishing. Avoid using hard objects such as knife blades and certain abrasive/souring agents as it is possible to introduce surface scuffs and scratches. Scratching is particularly noticeable on sink drainer areas. These are usually superficial and can be removed with proprietary stainless steel cleaners or, alternatively, with a car paint restorer, such as 'T-cut'. Rust marks or staining on stainless steels is unlikely to be the result of corrosion to the stainless steel itself (similar marks may also be found on porcelain and plastic sinks). These marks are likely to result from small particles of carbon steel from wire wool.

STANDARD FEATURES

Cart Saddle: Fabricated of 14 gauge stainless steel with #4 satin finish, the saddle is completely welded with no overlapping seams or gaps. All exposed welds are ground smooth and grained to match a #4 satin finish.

Cart Frame: Material on the cart frame is 1-1/2" square 16 gauge stainless steel tubing with all continuous bead weld with 1/8" radius bead.

Casters: Heavy-duty 8" diameter casters are provided with three wheel brakes and one swivel lock.

Welds: All welding is TIG type welding utilizing only stainless steel as a filler media. All weld fillets are approximately 1/8" diameter and are brushed clean removing any weld burrs or discoloration.

Corner Bumpers: Mounted on the cart saddle to help protect walls and doors from accidental bumps

Both the **JC100** 23" wide x 77" long and **JC101** 27" wide and 77" long Stainless Steel Body Trays offer the standard 1 inch rolled edge construction and is fabricated of 18 gauge stainless steel with a #4 satin finish. All corners are welded with a continuous bead. Two hand slots are provided on each end of the tray for easy handling. A drain hole and plug can be added at the time of order. The weight capacity of the JC100 and JC101 is 375 pounds.

WARRANTY

LIMITED WARRANTY

Products manufactured by Mopec will be free from defects in material and workmanship and conform to Mopec's description or specifications. If a warranty claim is made within one (1) year from the earlier of the date of acceptance/first beneficial use, the defective or nonconforming Product or Part thereof will be repaired or (at Mopec's option) replaced free of charge, FCA Mopec's dock. All warranty claims must be in writing and received by Mopec within the warranty period. The warranty is not transferable (other than to customers of Mopec's authorized Distributors), and will not apply unless the Equipment has been properly installed, maintained and operated in accordance with all instructions; and does not apply to defects, nonconformities or other failure due to Equipment misuse, abuse, modifications, or other causes outside Mopec's control. If a warranty claim is made in writing within the warranty period, the defective or nonconforming Equipment (or Part thereof) will be repaired or (at Mopec's option) replaced free of charge, FCA Mopec's dock.

THERE ARE NO WARRANTIES WHICH EXTEND BEYOND THE DESCRIPTION ON THE FACE HEREOF. THE WARRANTY AS SET FORTH HEREIN IS IN LIEU OF ALL OTHER WARRANTIES, EXPRESS OR IMPLIED, INCLUDING ANY IMPLIED WARRANTY OF MERCHANTABILITY OR FITNESS FOR A PARTICULAR PURPOSE.

To the extent that Mopec is acting as a supplier of Products manufactured by a third party, the Products will be warranted only to the extent that they are warranted by their manufacturers and Buyer (or its customer) agrees to look solely to the Product manufacturer for all warranty claims.



CERTIFICATE OF REGISTRATION

This is to certify that

MP Acquisition, LLC DBA Mopec

21750 Coolidge Highway, Oak Park, Michigan 48237 USA

operates a

Quality Management System

which complies with the requirements of

ISO 9001:2008

for the following scope of registration

The registration covers the quality management system for the design, engineering, manufacturing and installation of equipment and distribution of supplies for morgue, pathology, histology and necropsy applications.

Certificate No.: CERT-0078089
File No.: 1068177
Issue Date: March 11, 2014

Original Certification Date: April 9, 2008
Current Certification Date: April 7, 2014
Certificate Expiry Date: April 6, 2017

Chris Jouppi
President,
QMI-SAI Canada Limited

Samer Chaouk
Head of Policy, Risk and Certification



ISO 9001



Registered by:
SAI Global Certification Services Pty Ltd, 286 Sussex Street, Sydney NSW 2000 Australia with QMI-SAI Canada Limited, 20 Carlson Court, Suite 200, Toronto, Ontario M9W 7K6 Canada (SAI GLOBAL). This registration is subject to the SAI Global Terms and Conditions for Certification. While all due care and skill was exercised in carrying out this assessment, SAI Global accepts responsibility only for proven negligence. This certificate remains the property of SAI Global and must be returned to them upon request.
To verify that this certificate is current, please refer to the SAI Global On-Line Certification Register: www.qmi-saiglobal.com/qmi_companies/



MOPEC DD SERIES AUTOPSY CART

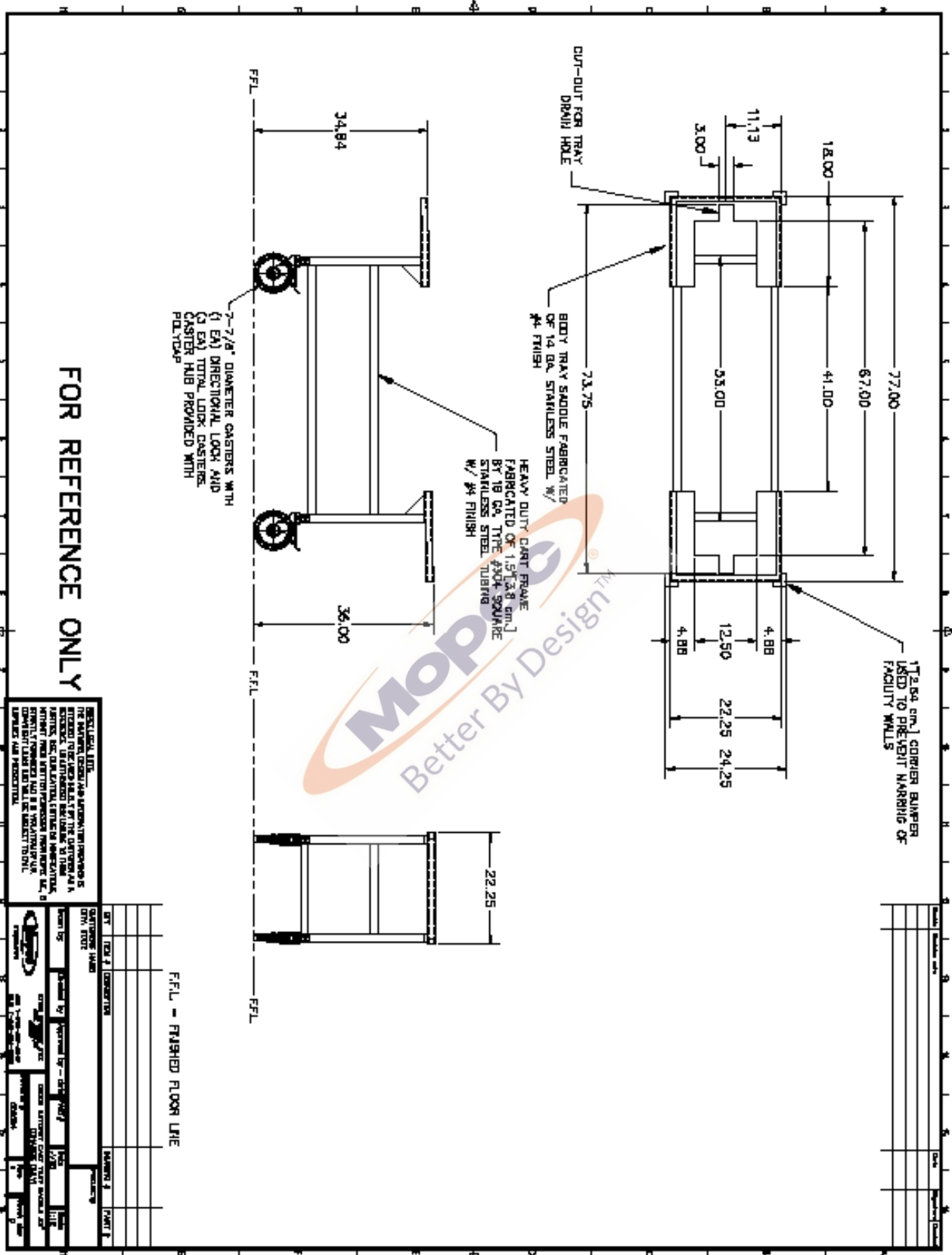

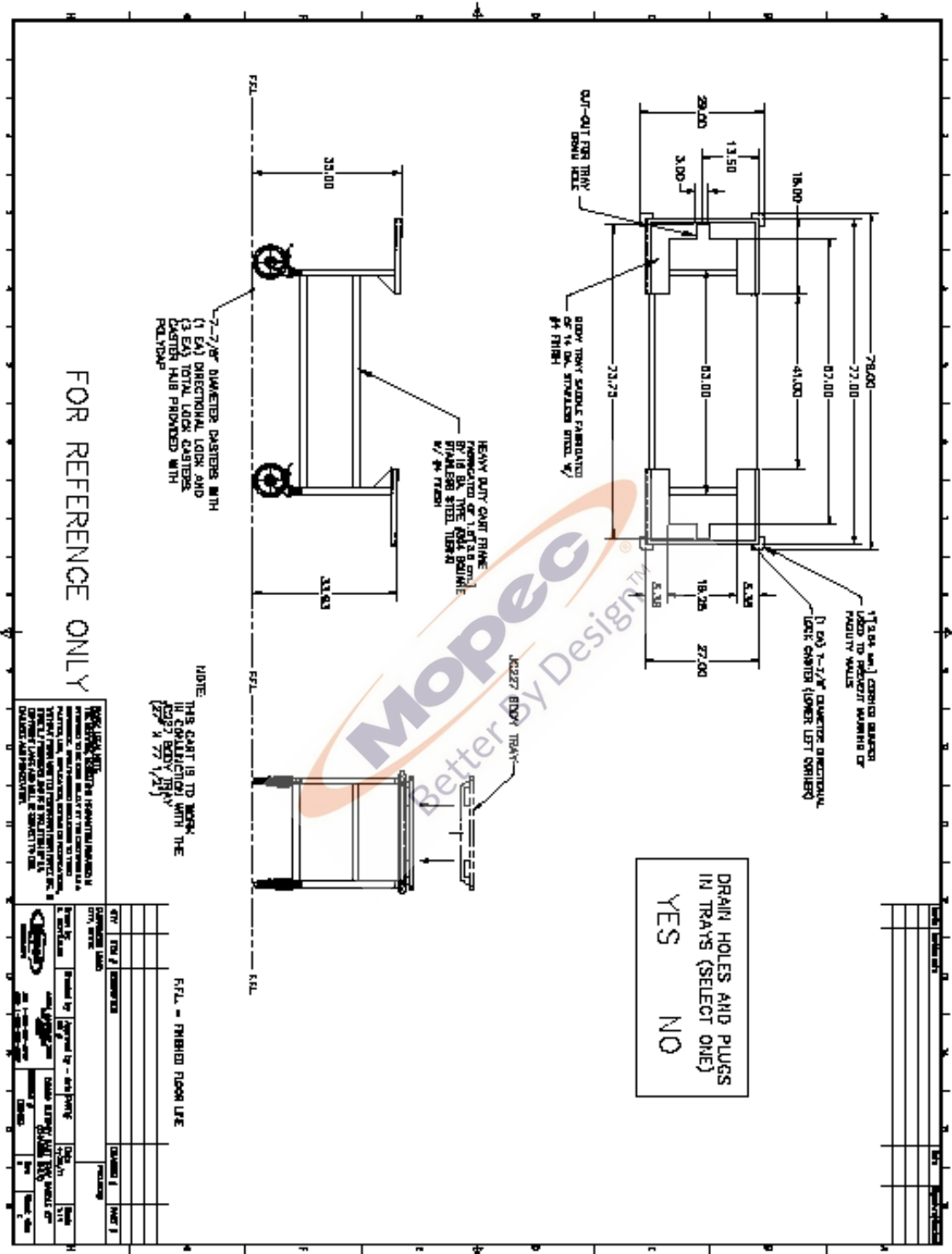

MOPEC DD SERIES AUTOPSY CART

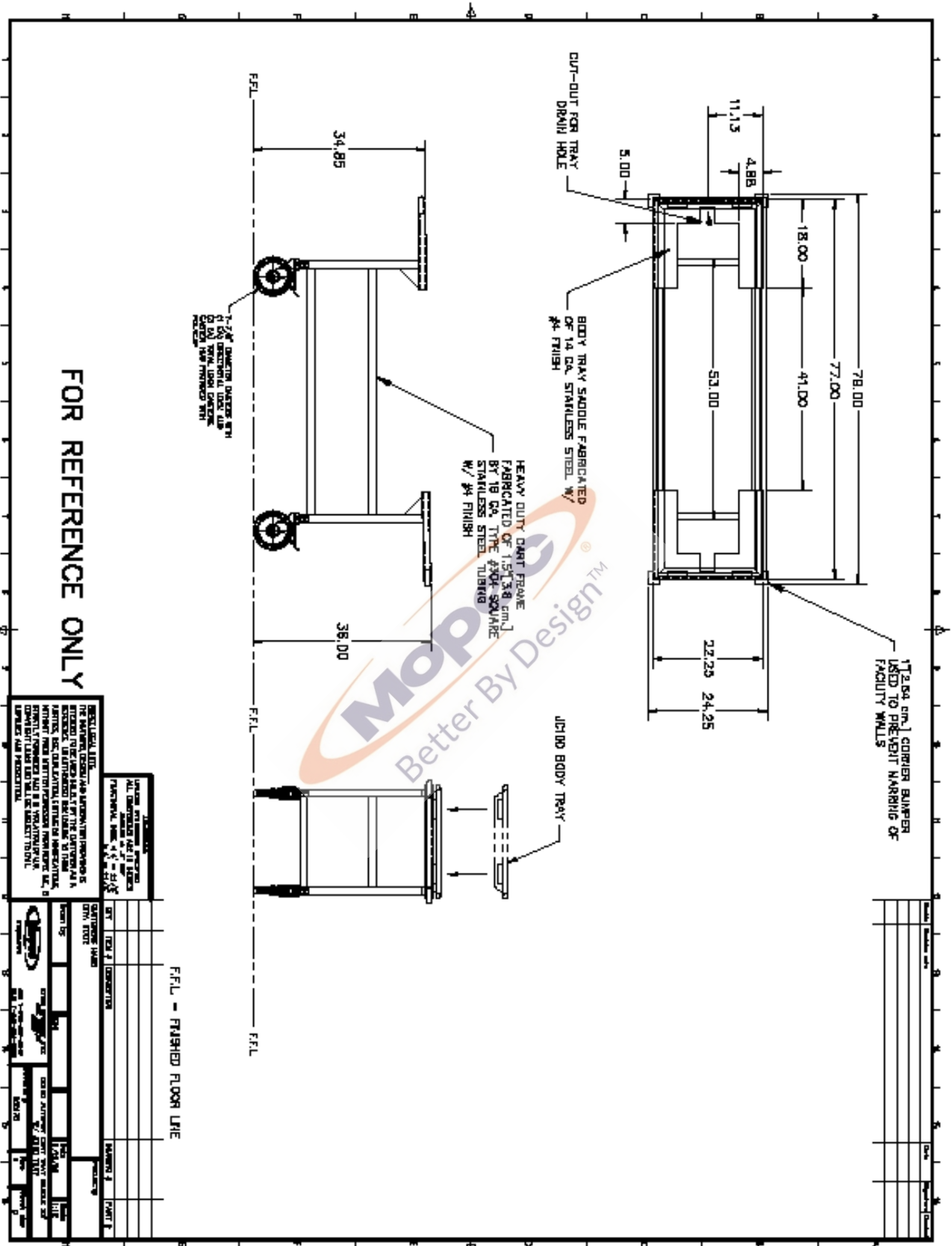

THE MATERIALS, DESIGN AND MANUFACTURING INFORMATION IS PROVIDED FOR YOUR REFERENCE ONLY. THE CUSTOMER SHALL BE RESPONSIBLE FOR OBTAINING ALL NECESSARY PERMITS AND APPROVALS FROM THE LOCAL, STATE AND FEDERAL AUTHORITIES. THE CUSTOMER SHALL BE RESPONSIBLE FOR OBTAINING ALL NECESSARY PERMITS AND APPROVALS FROM THE LOCAL, STATE AND FEDERAL AUTHORITIES.

REV.	DESCRIPTION	DATE	BY	CHKD.
01	ISSUED FOR MANUFACTURE	11/15/11	J. MOPEC	J. MOPEC
02	REVISIONS			
03				
04				
05				

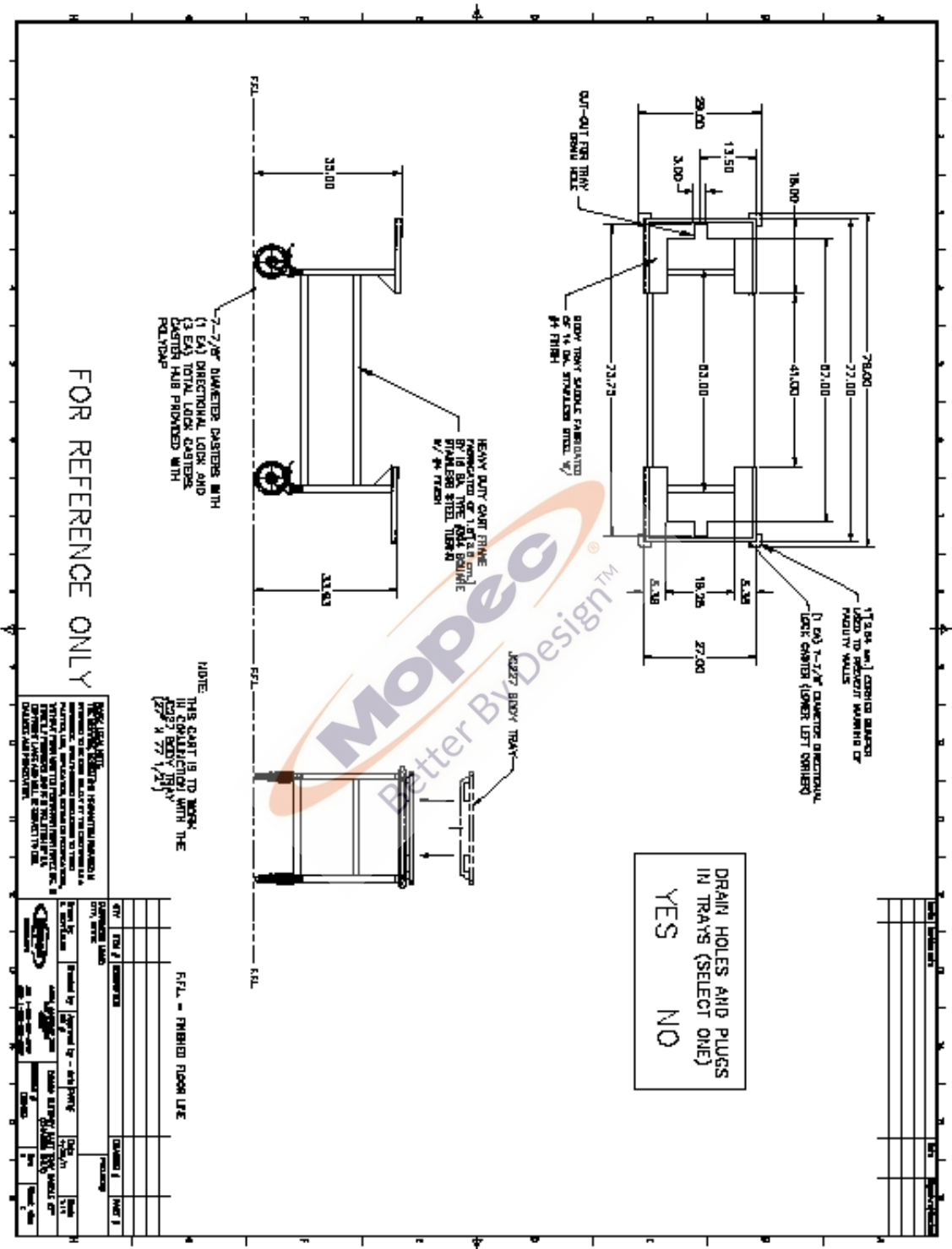



21750 Coolidge Highway • Oak Park, MI 48237 USA
+1 800-362-8491 • 248-291-2040 • Email: info@mopec.com